

Ph.D. selection test
Department of Physics
Indian Institute of Technology, Kanpur

May 10, 2018

Time : 9:30 – 11:30 AM

Maximum marks : 70

Question 1

(A) Use contour integration to evaluate

$$I = \int_0^{\infty} \frac{dx}{x^6 + 1}$$

Draw the contour and show clearly which part or parts of the contour contribute zero to the integral.

(4+2)

(B) (i) What are the singular points of the differential equation

$$2x^2 \frac{d^2y}{dx^2} + x(2x + 1) \frac{dy}{dx} - y = 0$$

(ii) Use the Frobenius series method to solve the equation. Find the first two terms in each of the series. **(1+3)**

Question 2

(A) The Lagrangian of a charged particle, with mass m and charge q , moving in an electromagnetic fields specified by the gauge potentials $\mathbf{A}(\mathbf{x}, t)$ and $\Phi(\mathbf{x}, t)$ is given by

$$L = \left(\frac{mv^2}{2} \right) + \frac{q}{c} \mathbf{A} \cdot \mathbf{v} - q\Phi$$

- (i) Find the conjugate linear momentum \mathbf{P} of the charged particle in presence of electromagnetic fields in terms of the mechanical momentum as $\boldsymbol{\pi} = m\mathbf{v}$. **(2)**
- (ii) Under a gauge transformation $\mathbf{A}(\mathbf{x}, t) \rightarrow \mathbf{A}'(\mathbf{x}, t) = \mathbf{A}(\mathbf{x}, t) - \nabla\chi(\mathbf{x}, t)$ and $\Phi(\mathbf{x}, t) \rightarrow \Phi'(\mathbf{x}, t) + 1/c \, d\chi(\mathbf{x}, t)/dt$, what is the new canonical momentum to \mathbf{P}' ? **(2)**
- (iii) What happens to $\boldsymbol{\pi}$ under the gauge transformation? **(2)**
- (iv) Does the Lagrangian of the charged particle in presence of electromagnetic field change under gauge transformations? If your answer is yes then show that this change in the Lagrangian does not affect the equations of motion of the charged particle. **(4)**

Question 3

(A) Using Poisson's brackets, show that the transformation $Q = q \tan p$ and $P = \ln(\sin p)$ is canonical. (4)

(B) Two equal masses m are connected to three identical massless springs with spring constant k as shown in the upper figure below with outer springs connected to fixed points A and B. The masses are free to move on a frictionless table AB. Their displacement vectors are as shown in the lower figure.

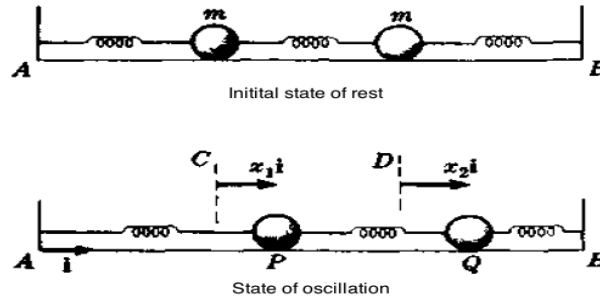

- (i) Write the Lagrangian for the system and derive from it the equations of motion for each mass. (3)
- (ii) Obtain the eigenfrequencies of the system. (3)

Question 4

(A) A particle of mass m moves along the x -axis in the potential $V(x) = -A\delta(x)$, $A > 0$.

- (i) Find its energy and eigenfunction for the bound state. (2)
- (ii) If the particle in (i) moves in the potential $V(x) = -A[\delta(x - a) + \delta(x + a)]$, $A > 0$, in the figure below, plot schematically its ground- and excited- bound states clearly showing any special features of the wavefunction. [Please draw the figure in your answer book and plot there] (3)

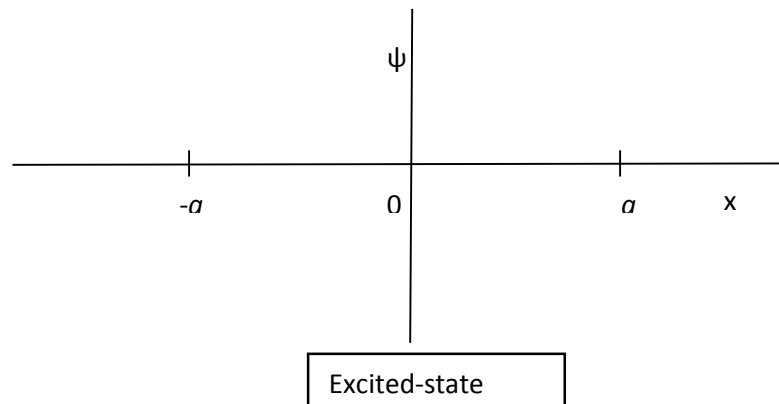
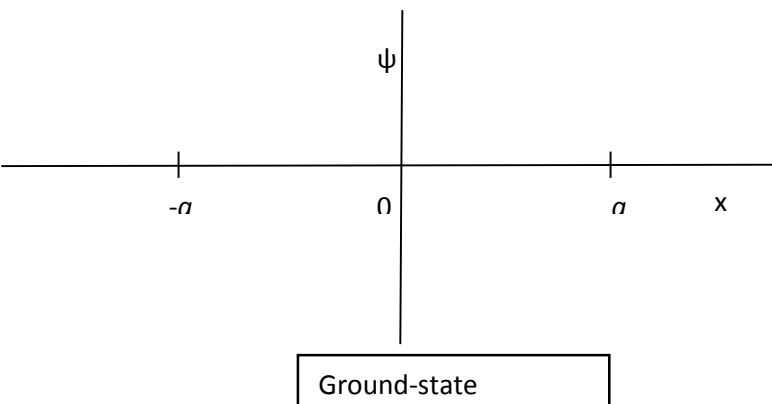

(B) A particle of mass m moves in the x-y plane in the potential $V(x, y) = \frac{1}{2}m\omega^2(x^2 + y^2)$. It is in the lowest energy eigenstate corresponding to the angular momentum \hbar and its wavefunction is of the form $\psi(\rho, \varphi) = R(\rho)\phi(\varphi)$. Find by explicit calculation:

- (i) the function $\phi(\varphi)$ **(2)**
- (ii) the dependence of $R(\rho)$ in the limit of both $\rho \rightarrow 0$ and $\rho \rightarrow \infty$. **(3)**

Laplacian in polar coordinates is:
$$\nabla^2 = \frac{1}{\rho} \frac{\partial}{\partial \rho} \left(\rho \frac{\partial}{\partial \rho} \right) + \frac{1}{\rho^2} \frac{\partial^2}{\partial \varphi^2}$$

Question 5

(A) Consider a system of N non-interacting one-dimensional harmonic oscillators in equilibrium with a heat reservoir at temperature T :

- (i) Taking the oscillators to be classical with Hamiltonian $H = \frac{1}{2}(p^2 + \omega^2 q^2)$, obtain the canonical partition function and hence the average energy of the system of oscillators. **(3+2)**
- (ii) If the oscillators are quantum mechanical with energy levels

$$\epsilon_n = \left(n + \frac{1}{2} \right) \hbar \omega, n = 0, 1, 2, \dots$$

where \hbar is the Planck constant, obtain again the average energy of the system of oscillators. In which limit, the expression for the average energy derived in this part reduces to that derived in part (i)? **(3+2)**

Question 6

- (A) An analog and a digital stopwatch can read at a precision of 1/10 of a second. Which one would you prefer to use to minimize error in your data collection and why? **(1)**
- (B) The time period T of a pendulum is measured in two different ways. In one experiment the total time for 10 oscillations (T_{10}) is measured and the time period is calculated as $T = (T_{10} / 10)$. In another experiment, time for each complete oscillation (T_1) is measured 10 times and the time period is calculated by taking mean, *i.e.* $T = \langle T_1 \rangle_{10}$. Calculate propagated measurement uncertainties in T and determine which between the two methods, statistically, gives more accurate value of the time period (neglect damping)? **(4)**
- (C) If a DC power supply is being used as a constant-voltage source with output voltage and maximum output current values set at V and I_{\max} respectively, then what would the range of load that can be attached? What would be the output current and voltage if a load beyond that range is attached to the power supply? **(3)**
- (D) What is a “True RMS” voltmeter? Write your answer in two sentences. **(1)**

Question 7

(A) Write the truth table for the logic circuit given below.

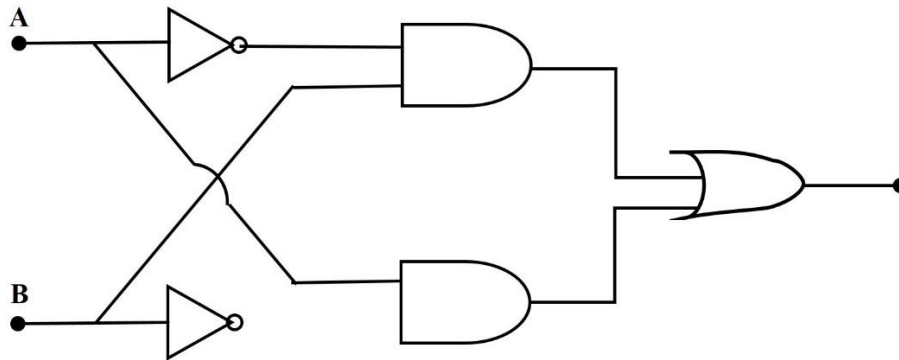

(B) A 5 mV, 1 kHz sinusoidal signal is applied to the input of an OPAMP as shown below. If $R = 100 \text{ k}\Omega$ and $C = 1 \mu\text{F}$, find the output voltage.

