

DIRECTOR'S REPORT

Honourable President of India, Shri Ram Nath Kovind; Honourable Governor of Uttar Pradesh, Shri Ram Naik; Honourable Chairman, Board of Governors of the Indian Institute of Technology Kanpur, Sri R.C. Bhargava; Members of the Board of Governors; Members of the Academic Senate; all graduating students and their family members; members of faculty, alumni, staff and student community; invited dignitaries, guests, and members of the media: I heartily welcome you all to the 51st Convocation of the Indian Institute of Technology Kanpur. I would also like to congratulate the graduating students and their families on this joyous occasion.

ACADEMIC ACTIVITIES

The academic session that ended in May 2018 has been truly satisfying, and I consider it a privilege to review our activities pertaining to this period.

I am pleased to inform you that the total number of Ph.D degrees awarded in this convocation is 186, which is an all time high record in the history of the Institute. To encourage the project based research the Senate approved a new academic programme MS (By Research) four years ago. I am delighted to let you know the first batch of 25 students in this program is graduating today. In all 1576 degrees are being awarded in this Convocation with the following details.

Degree	Number of recipients
PhD	186
MTech	307
MBA	39
M.Des.	21
MS (By Research)	25
VLFM	40

M.Sc. (5 year)	1
M.Sc. (2 year)	147
BTech-MTech (Dual Degree)	149
Double Major	11
BT-MBA (Dual Degree)	1
BT-M. Des. (Dual Degree)	1
BS-MT (Dual Degree)	1
MS-PD (MS part of Dual Degree)	13
BS-MS (Dual Degree)	56
BT-MS (Dual Degree)	9
B. Tech	505
BS (4 year)	64
Total	1576

Among 797 undergraduate students 147 students (i.e. 18.4%) students are graduating with distinction (CPI of 8.5 and above).

IIT Kanpur is known for offering most flexible undergraduate and dual degree programmes. Flexibility offered by these programmes has led to a large number of students graduating with minors (some with two minors) are highlighted below:

No. of students completing one Minor: 158

No. of students completing two Minor: 18

In addition by spending one year extra 11 UG students are graduating with a second major and 217 UG students are graduating with a masters degree along with a bachelors degree.

To keep pace with the evolving knowledge in science and technology space, 13 new Undergraduate and 39 new Postgraduate courses have been approved by the Academic Senate.

NEW INITIATIVES IN ACADEMIC COURSES

- **Curriculum Development and Monitoring Committee (CDMC)** to review, monitor, evaluate and revise pedagogy and incorporate the state-of-the-art methodologies in the field.
- **MS (Research)** programs in Aerospace Engineering from 2017 onwards and in Cognitive Science from 2018 onwards.
- **Biometric-based Attendance System** for UG classes to understand attendance patterns and to come up with ways to increase class attendance.
- **PMRF (Prime Minister's Research Fellowship)** by the Ministry of Human Resource and Development. In the academic year 2018-19, IIT Kanpur will be offering 48 admissions under this scheme.

NPTEL, SWAYAM PRABHA CHANNELS



In the last semester, IIT Kanpur's National Programme on Technology Enhanced Learning (NPTEL) Chapter supported Abdul Kalam Technical University (AKTU) by conducting a whitelisted course *Non-Conventional Energy Resources* for 45,000+ final year B.Tech students from 273 affiliated colleges.

- Under MHRD's Swayam Prabha initiative of taking education Directly to Home (DTH), 32 DTH channels have been started out of which IIT Kanpur is currently managing the channels 16 and 17. These channels broadcast the NPTEL course content in mechanical engineering, humanities and social sciences and management 24x7.

RESEARCH AND DEVELOPMENT

IIT Kanpur has registered steady growth in its research and development activities this year. Some of the highlights are mentioned below:

- 626 externally funded ongoing projects with a total sanctioned amount of Rs. 795 crore.
- 179 sponsored projects worth Rs. 182 crore
- 128 consultancy projects worth Rs. 23 crore.

Leading Funding Agencies of the year:

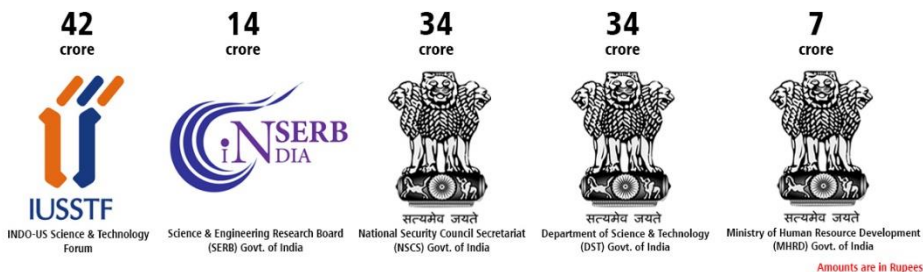

Leading Funding Industry Partners:



(A list of major projects granted this year is given at the end of the Report.)

MAJOR PROJECTS SANCTIONED

Indigenous 5g Test Bed Design: Funded by the Department of Telecommunication, a 5G testbed is being built in-house to enable Indian industry and academia to achieve the 5G technology development and implementation plans. This testbed will

demonstrate state-of-the-art 5G technologies such as massive MIMO, millimeter wave, IOT, and software-defined networking.

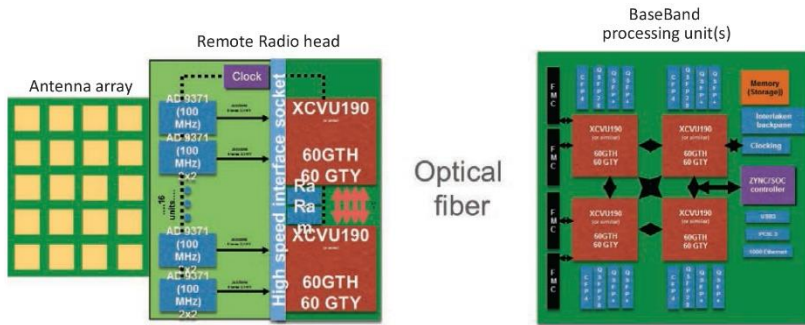

Design, Retrofitment, and Development of Methanol Fuelled Large Bore Engine for Locomotive, Marine, and Power Generation Applications: Funded by the Department of Science and Technology, the Institute and the Indian Railways (RDSO) are working closely to develop the world's first methanol fuelled locomotive engine that will significantly reduce the harmful particulate emissions without using any exhaust gas after treatment technology.

Design & Development of Aquatic Autonomous Observatory (Niracara Svayamsasita Vedhshala-NSVs) for In Situ Monitoring, Real-Time Data Transmission & Web-Based Visualization: funded by IUSSTF, it is a collaborative project between IIT Kanpur and WHOI, USA to develop a low-cost, multi-parameter, water quality platform that will have several in-house developed sensors and auto-sampling capability for durable and reliable real-time monitoring of Indian Rivers.



Air Quality Monitoring Streaming Analytics on Temporal Variables from Air Quality Monitoring (SATVAM): Funded by Indo-US Science and Technology Forum, it is a large, multi-institutional project with IIT Bombay and IISc as collaborating institutes from India and Duke University, USA. . Lack of spatially and temporally distributed air quality information does not enable a scientific study of its impact on human health and the national economy. The key objective of this project is to scale air quality monitoring by developing low-cost, energy self-sufficient air quality sensors that can be calibrated on the fly to transmit data seamlessly via cloud servers. A system like SATVAM will allow policymakers and citizens at large to deploy data-driven control and preventive mechanisms.

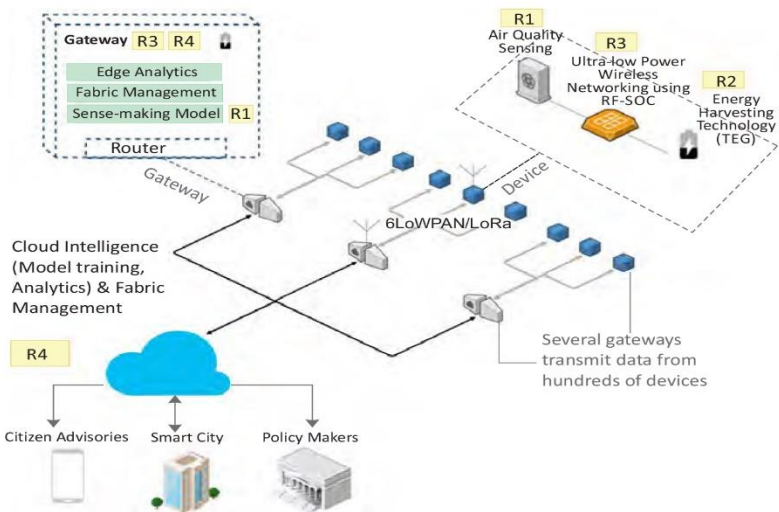

UI-ASSIST (US-India collaborative for Smart Distribution System with Storage): IIT Kanpur is leading a Pan-India consortium from technical institutes, utilities, and industries on a five-year joint Indo-US research project. The consortium from the USA is being led by Washington State University (WSU), Pullman, WA. Funded by DST, IUSSTF, US Department of Energy (DOE), the project aims at addressing the essential issues related to the

adoption and deployment of smart grid concepts along with distributed energy resources (DERs) including storage in the distribution network for its efficient and reliable operation. Analysis and technology tools for smart operations of interconnected microgrids including DER and storage will also be developed. In addition to developing technical solutions, the project will also investigate the social acceptance, impact, and value of the integrative solutions of smart meters, renewable energy, storage and microgrid solutions, along with the policy implications.

A key component of the joint program is the demonstration of the technology at ten lab level pilots and ten field demonstration pilots covering the rural, semi-urban and urban settings involving residential, commercial and industrial consumers.



Development of Nano-Bio-Platforms For Early Diagnostics of Chronic Diseases: Funded by the Department of Science and Technology, it aims to fabricate nanobiotechnology-based platforms for early-stage biomarkers for diagnosis of oral cancer, Mycobacterium tuberculosis, and related pathogens, using samples sourced from saliva and other body fluids. The proposed

deliverables include paper-based, microfluidic chip for early diagnosis of oral cancer and formation of 3D-cryogel matrices for cancer growth modeling through bioprinting approach, and an Electrochemical sensor for TB detection and peptide-based matrices for pathogen neutralization.

Development of National Blockchain and Demonstrate two Strategic Applications: Funded by National Cyber Security Coordinator (NCSC), IIT Kanpur will research and develop indigenous blockchain platforms which while cryptographically secured will enable transparent and efficient e-governance. The project is planned in 3 phases, first a feasibility study and identification of agencies to pilot with, research and prototyping phase, and finally an incubation phase. In the incubation phase, an IIT Kanpur incubated company will produce the solution and provide solution engineering to various agencies for blockchain based transparent e-governance.

Center for Energy Regulation (CER) - Strengthening Regulatory Research & Network in the Power Sector: Funded by the Department for International Development (DFID), Government of UK, the Center will enhance regulatory research and networking to understand and analyze the key issues in the Indian power sector, while working in close cooperation with Electricity Regulatory Commissions (ERCs), electric utilities and the academia. It also aims to develop networks with institutions in India and abroad.

The SPICE model titled ASM- THEMT has been selected as the world's first industry standard model for Gallium Nitride High Electron Mobility Transistor (GaN HEMT) by Silicon Integration Initiative's Compact Model Coalition (CMC). The Industry standard models are selected after rigorous evaluation and validation of multiple technologies by the semiconductor industry. The model will now be available in Electronic Design Automation software, and will be used by major semiconductor and EDA companies worldwide. GaN HEMT is widely used in RF

power amplifiers and power electronics applications. GaN HEMTs will be key to design power amplifiers for future 5G technology. The Government of India is considering setting up a GaN foundry near Bengaluru. DRDO and ISRO are also actively working on developing this technology for defense and space applications.

RESEARCH INFRASTRUCTURE

The Department of Aerospace Engineering received a FIST grant of DST with total support of Rs. 4.53 crore approximately for a five-year period to strengthen the research facilities. This funding support is being used to help initiate/expand the research capability in the following areas:

- High enthalpy high speed flows
- Advanced flow diagnostics
- Improving the mechanical integrity of aerospace materials
- Unmanned Aerial Systems.

The following cutting-edge equipment/facilities will be developed with this funding:

- Free Piston/Expansion Tube Facility and essential instrumentation
- Nd YAG Laser (for upgradation of existing equipment)
- Multi-Material Laser Sintering system
- Rayleigh Thermography setup
- Coherent Anti-Stokes Raman scattering (CARS) setup.

The Department of Electrical Engineering also received FIST grant of DST. The funds are being used for setting up:

- power-device and load-pull characterization system for high power IV, noise, and large-signal high-frequency measurements of nanoscale CMOS and power devices,
- time-resolved correlation measurement system for photonic devices
- Reliability evaluation system for power electronic converters
- Automated antenna positioner system for characterization of three dimensional radiation patterns of antenna in the Department's anechoic chamber.

Some of the other sophisticated facilities set up in the Institute during this year are listed at the end of this report.

INDUSTRY COLLABORATION

IIT Kanpur, being a premier technological institute in the country, works closely with industry partners with the objective of adding value to their products and services, the larger goal being to bring in novel solutions to the society at large.

This year, the Institute undertook to prepare a policy document on EVs & HVs vs FFVs in India for Maruti Suzuki India limited. An MOU was also signed in this regard.

NETRA initiated a few projects with Civil and Electrical Engineering departments in addition to what is already in progress in the Electrical and Aerospace Engineering departments.

PROJECTS UNDER UAY

(UAY)
Uchchatar Avishkar Yojana



IIT Kanpur has obtained approval for four projects under the Uchchatar Avishkar Yojana,

Ministry of Human Resource and Development:

- *Aircraft Engine Combustor Design for Improved Operability, Durability, Pattern Factor and Emissions* in collaboration with GE India Industrial Private Limited
- *Development of Polymeric Biodegradable Packaging Materials* in collaboration with Reliance India Limited
- *Addressable Peptide-Polymer Electrospun Nanofibers for Cell Sorting, Diagnostics and Delivery* with E-Spin Nanotech Pvt Ltd.
- *Fabrication of New Generation Self-Resorbing Implants and Devices from Bioactive and Biodegradable Materials for Orthopedic Applications* with Ortho Regenics Private Limited.

IIT Kanpur celebrated National Science Day on February 28, 2018 with a thematic workshop on 'Science and Technology for a Sustainable Future', organized by the Centre for Environmental Science and Engineering (CESE). The Institute celebrated



National Technology Day on May 11, 2018. The event was organized by the National Centre of Flexible Electronics (NCFlexE), IIT Kanpur Prof. Y.N. Mohapatra delivered a lecture titled, "What if Electronics is Flexible?" and more than 400 school children attended the talk.

INNOVATION AND INCUBATION

During the year, 53 patents including 8 design patents were filed, and 21 previously filed patents were granted, besides one technology titled "Anti-Counterfeiting Mark with 3-D Features" getting licensed for commercialization.

Till date, 35 design patents and 451 Indian patents have been filed, out of which 84 patents have been granted so far along with 56 technologies licensed for commercialization.

A total of 57 companies are currently incubated at SIDBI Innovation and Incubation Centre (SIIC), IIT Kanpur and 48 have graduated so far.

BIRAC has approved the second phase of funding of Rs. 1.9 crore under its scheme entitled BioNEST (Bioincubators Nurturing Entrepreneurship for Scaling Technologies) to provide financial support for the expansion of BIRAC-Bio-NEST Facility at IIT Kanpur.

SIDBI Innovation and Incubation Center (SIIC) at IIT Kanpur has been selected as the 6th Biotechnology Ignition Grant (BIG) Partner of DBT for BIRAC's flagship programme BIG.

BIRAC has approved seed fund of Rs. 100 lakh to provide funding to the start-up companies in Biotech space up to Rs. 30 lakh per startup as equity support.

National Research & Development Corporation, New Delhi has given funding to setup Innovation Facilitation Centre (IFC) at IIT Kanpur. The Innovation Facilitation Center has the mandate of promoting the Innovation Ecosystem and has facilitated filing of 53 Patents during the financial year 2017-18.

Some of the awards of SIIC and its incubatee companies are listed in the table below:



Award	Recipient
ISGF Innovation Award 2018 – Smart Incubator of the Year	SIDBI Innovation & Incubation Centre
TiE UP Award 2018 - Young Entrepreneur of the Year	GT Silicon Private Limited and Inertial Elements
Winner at the GSEA South Asia Final Competition	PROSOC Innovators
Finalist of Ericsson Spirit of Entrepreneurship Award, IUSSTF Innovation Award	Kritsnam Technologies

Other achievements:

- Aarav Unmanned Systems has raised an undisclosed amount in pre-Series funding from GrowXVentures, 500 Startups and BellWether Advisors in March 2018. The first round of funding was received by StartupXseed, 3ONE4 Capital and Sanjay Jesrani aided by ValPro's Enablers.
- APCEGEN Technologies has been selected by DBT to represent Indian Pavilion at Boston in May 2018.
- Oxen Farm Solutions was acknowledged at Rashtrapati Bhawan in their program for modernizing agriculture.
- Krishi Hub was recognized as Top 10 Agriculture Solutions Provider by Silicon India Startup City.
- National Center for Flexible Electronics at IIT Kanpur has developed one of a kind technology for detecting fake goods. Transpacks Technologies incubated at SIIC manufactured one lakh such labels and shipped to a multinational company.
- Help Us Green, a company incubated at SIIC, has developed the world's first temple-waste solution. The company has a total of 6 patents are in the pipeline. For the financial year 2018, the revenue rate for the company is around Rs. 2 crore and funding amounting to \$356,000 has been raised till date from various funders. Help Us Green has been featured in Forbes 30/30, CNBC Awaaz, and Stanford Special Review.
- The incubation and innovation ecosystem at IIT Kanpur is being professionalized by means of a Section 8 company.

INTERNATIONAL ACADEMIC COLLABORATIONS

Recognizing the value of international cooperation, the Institute has signed MoUs with many foreign institutions for collaboration in academic and research activities.



The list includes Ecole Nationale Supérieure D Arts et Metiers from France; Heidelberg University and Faculty of Management and Economics of Leipzig University from Germany; Katanov Khakass University from Russia; University of Seville and University of Santiago de Compostella from Spain; University of Buffalo from the USA; Sharif University of Technology and Alazahra University from Iran; Nanjing University of Science and Technology from China; Shibaura Institute of Technology and School of Engineering, Graduate School of Information Science and Technology and University of Tokyo from Japan, amongst others.

FINANCIAL RESOURCE MOBILIZATION

(In Rs. lakh)

S No.	Comparative Heads	Comparative Statement of Donations	
		2016-17	2017-18
A	Donations	762	1076
A1	On the basis of origin		
1	Domestic	249	353
2	Foreign	513	723
A2	No. of Donors	461	2234
1	Domestic	266	1613
2	Foreign	185	621
A3	No. of Donations	547	2564
A4	Notable Contributions under different initiatives		
1	Infrastructure and Social Initiatives	439	551
2	Academic and Student Initiatives	89	173
3	Batch Contributions	88	121
B	Corporate Social Responsibility		
1	MoU signed with no. of companies	7	4

2	Total value of MoU signed/extended	985	167
3	Funds received during the year for all MoU signed till closing of Financial Year	145	330

NOTABLE CONTRIBUTIONS ARE AS FOLLOWS:

Purpose	Amount (in Rs.)
Class of 1963 Batch Fund	26,81,820
Class of 1968 Batch Fund	51,32,962
Class of 1993 Batch Fund	23,18,951
Class of 1997 Batch Fund	13,16,210
Opportunity School Building	1,96,31,525
Motwani Incubator & Accelerator	3,21,28,750
Student Endowment Scholarship (Low income group)	35,77,571
Mrs. Ratna Kaushik & Dr. Bhooshan Lal Scholarship	10,00,000
Sandeep & Vineeta Agarwal Scholarship	6,75,000
Tarun Sondhi Memorial Scholarship	6,84,000
Prof. Sanjeev K Agrawal Endowment Fund	26,19,921

Students-Undergraduate Research & Graduate Excellence (SURGE), an outreach program for students from other institutions in the country, supported by alumni contributions, was conducted during the summer of 2017. The selection of participants is highly competitive as thousands of applications from various institutions are received, and this testifies to the

increasing popularity of the program among students across the nation.

No.	Particulars	SURGE 16	SURGE 17
1.	No. of Applications	1600	1200
2.	No. of Participants	92	103
3.	No. of faculty members from IIT Kanpur mentoring	73	73

ALUMNI IMPACT

A. Notable achievements in the field of Science and Technology by our alumni:

Our distinguished and respectable alumni have been proud recipients of various honours and awards in various categories during F.Y. 2017-18 as shown below:

Category of Award	Number of Awards
Academic Awards	60
Industrial Awards	4
Government Awards	2

Some of the major achievements are as follows:

Award	Name of Alumni	Award Endowed by
College of Fellows	Prof. Kalpana Katti (MSc2/PHY/1989)	American Institute for Medical and Biological Engineering

2018 Guggenheim Fellow, Member of National Academy of Sciences	Prof. Arup K. Chakraborty (BT/CHE/1983)	John Simon Guggenheim Memorial Foundation, National Academy of Sciences
Fellowship	Prof. Debabrata Goswami (MSc2/CHM/1988)	Institute of Physics
Fellowship	Prof. Sudeshna Sinha (MSc5/CHM/1985) Prof. Sandhya S. Visweswariah (MSc2/CHM/1980) Prof. Shiraz N. Minwalla (MSc5/PHY/1995) Prof. Amitabha Chattopadhyay (MSc2/CHM/1980)	The World Academy of Sciences
Member	Prof. Jayadev Misra (BT/EE/1969) Prof. Mukul Mani Sharma (BT/CHE/1980) Prof. Ashok Jhunjhunwala (BT/EE/1975)	National Academy of Engineering
Padma Shri 2018	Mr. Arvind K. Gupta (BT/EE/1975)	Republic of India
H. K. Firodia Vijnan Bhushan Award 2017, UNESCO Medal 2017	Prof. Ashutosh Sharma (BT/CHE/1982)	HK Firodia Foundation, United Nations Educational, Scientific and Cultural Organization

PLuS Alliance Prize 2017	Dr. N. R. Narayana Murthy (MT/EE/1969) Prof. Veena Sahajwalla (BT/MME/1986)	The PLuS Alliance
Foreign Associate of National Academy of Sciences	Prof. Manindra Agrawal (BT/PhD/CSE/1986/1991)	National Academy of Sciences

B. Notable entrepreneurial endeavours by some of our alumni:

Name of the Alumni	Entrepreneur in the field of
Rohit Garg (BT/CSE/2006)	Co-founder of Bengaluru-based fintech startup 'Smart Coin'. The company has raised \$2 million (Rs 13 crore) in a pre-Series A funding round. Smart Coin is a consumer micro-lending platform focused on the underserved middle and lower-income segments in India. It has successfully disbursed 50,000 microloans so far.
Nikhil Upadhye (Dual/CE/2013) Sahas Banshiwala (Dual/EE/2013)	Co-founders of Aarav Unmanned Systems (AUS). The company has raised an undisclosed amount in a pre-Series A round led by GrowX Ventures, 500 Startups and Bellwether advisors. The Bengaluru-based company designs and develops drone-based solutions for mapping, industrial

	inspection and precision agriculture using its own proprietary drone technology.
Mr. Deepak Garg (BT/ME/2003)	Founder of 'Rivigo', a technology-enabled logistics company. The company has raised Rs. 322.5 crore in Series D round. The company has its own fleet of 2000+ trucks, a pan-India network, best transit time performance and customized solutions such as LPCD.
Mr. Varun Khaitan (BT/EE/2009)	Co-founder of UrbanClap, a Gurugram based home services start-up. The company has raised \$21 million Series C funding from Internet investment fund Vy Capital.

C. Important positions held by some of our alumni:

Name of the Alumni	Position
Prof. K. VijayRaghavan (BT/MT/CHE/1975/1977)	Appointed the Principal Scientific Adviser to the Government of India.
Prof. Chandramauli Agrawal (BT/ME/1982)	Appointed the Chancellor of the University of Missouri-Kansas City.
Dr. Mohit Uberoi (BT/CHE/1986)	Appointed the CEO of Gerber Technology, the world leader in integrated software and automation solutions for the apparel and industrial markets.

INSTITUTE FACULTY

Recruitment

In the past one year, the Institute has offered 40 faculty positions against a rigorous selection from 855 applicants. Out of these, 23 new faculty members have joined the Institute. The appointments per department are mentioned below:

Department	Number of new faculty
Aerospace Engineering	5
Chemical Engineering	1
Civil Engineering	1
Computer Sciences & Engineering	5
Earth Sciences	1
Electrical Engineering	2
Industrial & Management Engineering	2
Mathematics & Statistics	2
Mechanical Engineering	2
Physics	2

During this period, we have also made 9 offers of post-doctoral fellowships, 8 visiting faculty, 12 adjunct faculty, and 2 Distinguished Honorary Professors.

Awards and Honors

I am extremely happy to share with you that a paper authored by Dr. Arun Shukla (BSBE) and Dr. Anand K. Jha (PHY) is published in a prestigious journal named *Nature Nanotechnology* and *Nature Communications* respectively.

Dr. Abhishek (AE) has been chosen for the Abdul Kalam Technology Innovation Fellowship of INAE for three years. Dr. S. Ganesh (BSBE) received Tata Innovation Fellowship (2017-2020) by Dept. of Biotechnology (DBT), Ministry of Science and Technology, Govt. of India. Dr. Yogesh M Joshi (CHE), Dr. Amalendu Chandra (CHM), Dr. Sankar P. Rath (CHM) have been elected Fellow of National Academy of Sciences, India. Dr. Rahul Mangal (CHE), Dr. Vishal Agarwal (CHE) received Ramanujan Fellowship, SERB, Govt. Of India. Dr. J N Moorthy (CHM) and Dr. J. K. Bera (CHM) have been elected Fellows of the Indian National Science Academy, New Delhi. Dr. Surender Baswana (CSE) received Humboldt Fellowship for Experienced Researchers from Humboldt Foundation of Germany. Dr. Laxmidhar Behera (EE) has been elected Fellow of the Indian National Academy of Engineering (INAE). Dr. Sandeep Anand (EE), Dr. Joydeep Chakraborty (PHY) and Dr. Somnath Jha (M&S) have been selected Associates of the Indian Academy of Sciences, Bangalore. Dr. Anindita Chakrabarti (HSS) has been elected a Senior Fellow, Humanities Centre for Advanced Studies (2016-2020) of Leipzig University. Dr. Kumar Ravi Priya (HSS) received Fulbright-Nehru Academic and Professional Excellence Fellowship-Flex Award by USIEF. Dr. Sameer Khandekar (ME) has been elected Fellow of Institution of Engineers (India). Dr. Kantesh Balani (MSE) received Swarnajayanti Fellowship Award 2016-17 of Department of Science and Technology, Govt. of India. Dr. Krishanu Biswas (MSE) has been elected Young Fellow of Global Young Academy (GYA), Germany. Dr. A.K. Singh (MSE) received the Fellowship of the Indian Institute of Metals.

Dr. Debopam Das (AE) has been awarded the 'Best Professor in Aerodynamics' in the subcategory: Education Leadership Award by Dewang Mehta National Education Awards. Dr. Arun Shukla

(BSBE) has been selected for the B.M. Birla Science Prize in Biology for the year 2016. Dr. Arun Shukla (BSBE) has been selected European Molecular Biology Organization's (EMBO) Young Investigator. Dr. Sachchida N Tripathi (CE), Dr. Manindra Agarwal (CSE), Dr. Vinod K Singh (CHM) and Dr. Sandeep Verma (CHM) have been chosen for felicitation by the Government of Uttar Pradesh. Dr. Yogesh M Joshi (CHE) received RPG Life Sciences M. M. Sharma Gold Medal by Indian Institute of Chemical Engineers. Dr. Ashutosh Sharma (CHE) was honored with the UNESCO Medal 2017 for contributions to and development of nanosciences and nanotechnology. Dr. K. Srihari (CHM) and Dr. A.K. Chaturvedi (EE) (presently Director, IIT Roorkee) have been awarded the prestigious INSA Teachers Award (2017). Dr. Jitendra K. Bera (CHM) has been selected for the C. N. R. Rao National Prize in Chemical Sciences 2018. Dr. Sandeep Verma (CHM) has been selected for the MRSI-ICSC Superconductivity & Materials Science Annual Prize by the Material Research Society of India for the year 2018. Dr. T.V. Prabhakar (CSE) received Teaching Innovator Award-2016 by MHRD, New Delhi. He also received SKOCH GOLD Award in the category of "Technology for Growth" for the AgMOOC project. Dr. Amey Karkare (CSE), Dr. Purushottam Kar(CSE) and Dr. T V Prabhakar (CSE) received Best faculty of the year in the category of Evangelizing and Contributing to Spread of knowledge across several Institutions; Innovative Application of Technology Tools in Teaching/Learning; Authoring Books On Contemporary Subjects respectively by the Computer Society of India, Mumbai Chapter. Dr. Sandeep Anand (EE) has been selected for the INAE Young Engineer Award 2017. Dr. Debasis Kundu (M&S) received P.C. Mahalanobis award by Operation Research Society of India. Dr. Avinash Kr. Agarwal (ME) received the 6th edition of the India Research Excellence- Citation Awards by Clarivate Analytics. Dr.

Gautam Biswas (ME) (presently Director, IIT Guwahati) has been awarded Honorary Doctorate (Honoris Causa) by NIT Agartala. Dr. Sudhanshu Shekhar Singh (MSE) received Young Metallurgist of the Year 2017 Award by The Indian Institute of Metals (IIM), India. Dr. Ashish Garg (MSE) received Newton Prize Award for DST-RCUK APEX Project by UK National Commission for UNESCO. Dr. Kallol Mondal (MSE) received Mascot National Award by Electrochemical Society of India. Dr. Krishanu Biswas (MSE) received Metallurgist of the Year, 2017 in Metal Sciences Category by Ministry of Steels, Government of India. Dr. Surender Baswana (CSE) and Dr. Anish Upadhyaya (MSE) received Distinguished Teacher Award 2017 by Indian Institute Technology Kanpur. Dr. H.C. Verma (PHY) has been awarded the Maulana Abdul Kalam Azad Shiksha Puraskar-2017. Dr. Indranil Manna (Former Director) has been conferred the D.Sc. degree (Honoris Causa) of the University of Kalyani (WB) during the University convocation (7th September 2017).

The many prestigious scholarships and awards received by our students have been a matter of pride and pleasure for us. Shruti Agrawal, Saksham Sharma, Arihant Jain, Gargi Singh, Durgesh Rajendra Agrawal, Yugesh Ajit Kothari, Yatin Dandi, Anish Saxena received the Aditya Birla Scholarship. Snehangshu Paine received ACC Fellowship. Sudhir Kumar, Aayushi Bansal, Vipul Bajaj, Md. Wasim Alam received the O.P. Jems scholarship. Shivangi Ranjan, Kumar Kshitij Patel, Preetham Paul Sunkari received Honda Yes scholarship. Vandana Pawreya, Soumya Sahoo, and Apoorva Shukla received Pratibha Eaton Awards.

The full lists of awards received by the faculty and students are given at the end of the report.

STUDENTS' ACTIVITIES

The Institute has encouraged and enabled extra-curricular student activities to ensure that the students become well-rounded. The goal is to produce individuals who are not only technically competent but also have expertise in a range of skills of their choosing. Further, the Institute strongly believes that an abiding social and humane engagement is the hallmark of the empowered youth. To achieve this lofty vision, the Institute nurtures social, cultural and sporting activities pursued by the Students' Gymkhana, which itself is a self-governed body of the students.

Here are some of the achievements of the Students' Gymkhana:

Entrepreneurship Cell



Entrepreneurship Cell (E-Cell), IIT Kanpur is a non-profit student's organization dedicated to



promoting the spirit of entrepreneurship amongst the campus community.

The E-Cell established its importance and objective by successfully conducting its flagship event, eSummit 2017, which hosted several prominent entrepreneurs, industrialists, and

businessmen. Participation was large with an attendance of over 1,200 individuals. The event comprised talks and panel discussions by eminent personalities including the likes of Mr. B V R Mohan Reddy, Ex-Chairman NASSCOM, Mr. Sandeep Aggarwal, Co-Founder Shop Clues and Mr. Alope Bajpai, CEO Ixigo. Apart from these, 7 competitions and 5 workshops were conducted as part of this event which witnessed participation from over 300 colleges across the nation. E-Cell was also the host of the prestigious 'Samsung Innovation Awards' this year.

E-Cell also conducted Startup Master Class - the first-ever event at IIT Kanpur jointly organized by students and alumni. It helped campus entrepreneurs obtain real time investment and gain the association of influential agencies.

Every weekend the lecture-cum-discussion sessions 'Campus Hangouts' were organized, aimed at taking entrepreneurship off the books and into general conversations that lead to an increase in the involvement of the campus in entrepreneurial activities.

Vox Populi



Student journalism was designated as a separate cell under Students' Gymkhana this year. In its maiden year as a cell, Vox Populi furthered its online reach to 7,000 viewers, an increase of nearly 60%. The body published two print editions along with regular updates on its online handle to act as a pivotal link between the administrative perspective and the voice of the campus community. It reported on prominent issues like the Institute's proposal on the 'Institute of Eminence' program, major awards to students and faculty, updates of Inter IIT Sports Meet 2017, grievances of Visitors' Hostel workers and washerman community, the existence of

gender insensitivity and much more. The Senate Samachar series of Vox Populi kept the students updated on the proceedings of Students' Senate.

Community Welfare Cell

The Welfare Cell is a student group that is committed to learning, understanding and helping the society within the institute as well as in its vicinity. The different wings of the Cell worked on several important projects:

- Prayas worked in the field of education for the marginalized sections of the society. Apart from regular classes



held for the underprivileged children of the workers in the institute, the wing organized the Prayas Premier League, an annual function, a gender awareness session, a science week and a picnic.

- Prakriti worked in the field of environmental awareness, social innovations, and impact assessment. The group organized a paper collection drive, a tree plantation drive and a clothes distribution and cleanliness drive.



- Raktarpan is dedicated to remedying the shortage of blood and for this purpose it organized various blood donation camps and handled a total of 1140 helpline requests.



Outreach Cell

The Outreach Cell has taken several initiatives which have ensured that the campus outreach activities scale up. This included “That’s IIT,” an initiative to connect with the students and counsel them for smooth transition from their school life to deciding an appropriate college education program. Several alumni connected initiatives were taken, and a “Tips from the Top” session was organized. In its first year of inception itself, outreach cell was able to implement several initiatives that augur well for connecting with the society at large.

Students' Senate

The main policy drafting body of the Students' Gymkhana worked on and legislated various policies this year. Some of the major policies are mentioned below:

- Marketing Guidelines were framed for the Gymkhana to obtain sponsorship as a whole with a vision to make it self-sufficient.
- To streamline the functioning of the Senate, two new sub-committees were created, the Post-Graduate Student Affairs Committee (PG-SAC) and the Under-Graduate Student Affairs Committee (UG-SAC). These committees will opine on issues faced exclusively by the UG and PG communities respectively.
- Formation of a Gymkhana Award for Faculty - To appreciate the efforts some professors put in for the welfare of the students beyond their call, it was decided to institute an award for honoring such faculty.

Ek Bharat Shreshtha Bharat

Ek Bharat Shreshtha Bharat (EBSB) Cultural Day is one of the



major flagship programmes of the Government of India, to bring in cultural integration of the country as part of the vision to build a “New India by 2022”. Two such EBSB cultural days of partnering

states of Tamil Nadu and Jammu & Kashmir and Punjab & Andhra Pradesh were conducted, facilitating more community interactions and harmonious engagement of several cultures.

Science and Technology Council

It has been another glorious year for the Science and Technology Council. The achievements are:

Inter IIT Tech Meet 2018: Gold Medal, Technology for Soldier Support along with one silver and two bronze medals.

Techkriti 2018: Electronics Club won the Techkriti Innovation Challenge and Electrade, BRaIN hobby group won Biobuzz, Aeromodelling Club won Hover Mania and Sky Sparks.

Formula Bharat 2018: With their third formula vehicle, team SAE secured the 9th position in the Design event, 5th position in Business Logic presentation and an overall 15th position.



Aeromodelling Club won the Aerodynamix Competition held at MNIT, Allahabad

The Science and Technology Council organised various lectures and workshops in programming, robotics and aeromodelling.

Council members were invited for guest lectures and judging in Kanpur schools and colleges including HBTI and DPS Kalyanpur.

The Media and Culture Activities

A major initiative taken this year to push new talent to the stage was the open mic series. SPIC MACAY programs were organized to cultivate an appreciation for the indigenous cultural arts amongst the students.



Students of the council created a world record of origami structures by using the maximum number of origami pieces. The record is yet to be verified and cited by the Limca Book of World Record and Guinness Book of World Record.

Games and Sports Council

Diverse activities aimed at broadening the outreach of sporting activities among various segments of campus community were organized during the year. Some of the new initiatives were one-week-one-sport, archery workshop, aquatics in inferno etc.

IIT Kanpur participated in the 33rd Inter IIT Aquatics Meet held at IIT Madras and secured the first position in Water Polo (Men), third in Swimming (Men) and Swimming (Women).

The entire contingent participated in the coveted 52nd Inter IIT Sports Meet held at IIT Madras. We, the defending champions played our heart out and secured third position in the General

Championship tally. We stood 2nd in the Men's category and 4th in the Women's category. The weightlifting team secured the overall first position, the athletics (men) and the tennis (men) teams secured the second position; the basketball (men & women), the volleyball (women) and the cricket teams secured the third position. The weightlifting team set a new meet record.

IIT Kanpur hosted the U.P State Taekwondo Championship and Kanpur District Athletics Meet. Our chess team participated in the 6th Inter IIT chess meet at IIT Madras and showcased their talent. Archery and Wall climbing workshops were also conducted.

Adventure Sports Club increased their reach and frequency of treks. The trek to Bhutan has been one of the highlights. Taekwondo club organised belt promotion tests and self-defense workshops. Bicycling expeditions and regular local cycle trips were conducted by the bicycling hobby group. Regular workshops were conducted by all the clubs during the semesters. All the clubs carried out activities to engage the campus community during the summer vacations.

Festivals

Antaragni



The cultural fest, Antaragni, reached new heights in its 52nd edition where the team of our students successfully managed the festival which involved a footfall of more than 1 lakh with a budget of around 1.5 crore.

The theme of the festival was 'Suits of Euphoria', representing 52 years of its legacy and the sense of exuberance associated with the fest. The main festival lasted for four days, from 26th to 29th October 2017. These four days were filled with rich cultural performances where more than 200 colleges battled for glory, along with glamorous and enthralling performances from well-renowned national and international artists.

The star attractions of the fest included the world-renowned DJ KSHMR along with the Bollywood duo of Vishal Shekhar, the famous international band Sky Harbor which performed on top of the Red Bull Tour Bus and the all-time popular Indie-pop band Euphoria.

Techkriti

Techkriti, the annual inter-collegiate technology and entrepreneurship festival, was organized in March 2018 with



PRISM OF POSSIBILITIES as its theme. Shyam Benegal, the veteran Bollywood director, inaugurated the festival.

Apart from this, other speakers were Hon'ble MK Amir Peretz, Former Deputy Prime Minister and Former Defence Minister of Israel; Simon Taufel, umpire of the 2011 Cricket World Cup Finals and five times winner of the ICC Umpire of the Year; Dr. Moshin Wali, Padma Shri awardee and the youngest physician to the President of India; as well as Jitendra Nath Goswami, The Moon Man of India and Padma Shri awardee.

Some of the major exhibitions for this edition of Techkriti were ETH Zurich, Autonomous Soccer Playing Robot developed at ETH Zurich, Switzerland; NINO, the first Indian humanoid robot and Remidi the first wearable device to record, perform and play using hand gestures.

Techkriti also witnessed fierce competitions in events like Robowars, International Autonomous Robotics Challenge (IARC), International Robots Got Talent (IRGT), Techkriti Grand Prix (TGP), Techkriti Innovation Challenge (TIC), Multirotor, Sky Sparks, Embedded, IOT, Business and Entrepreneurial Events to name a few. Adding to it, the fourth edition of Techkriti Open School Championship was held in 19 cities in 3 rounds.

This time Technocruise, the zonal round of Techkriti was conducted in 13 cities.

Udghosh

Udghosh, the annual sports festival of IIT Kanpur continued its legacy of being the largest and most anticipated sports festival of India. The 2017 edition witnessed more than 40,000 people with more than 2,300 participants from more than 150 colleges all

across India. With the introduction of Kabaddi and Udaan (sports for specially abled), Udghosh broadened its horizon.

This year, Udghosh went one step further by welcoming one of the most prominent athletes of our country, Gold medalist in Olympics, Mr. Abhinav Bindra, as the Chief Guest at the closing ceremony.



Apart from sports, EDM nite (Club Banditz and Carnivore) and Comedy Night (Rahul Subramanian and Nitin Gupta) were also organized. The social initiative of Udghosh 2017 was conducted in collaboration with Suresh Raina's 'Gracia Raina Foundation' with Priyanka Raina arriving on the campus. Udghosh 2017 raised the bar sky high for upcoming editions.

COUNSELLING SERVICE

Overview and Team Strength

The Counselling Service (CS) primarily provides emotional, academic and financial assistance to students. CS consists of a team of professional counselors, psychiatrists and a group of student volunteers dedicated towards the welfare of the student community. Currently, there are 3 professional counselors, 2 assistant

counselors and 2 psychiatrists who regularly visit the Institute. The student team comprises an undergraduate wing and a post-graduate wing. The UG wing has 25 core team members, 139 student guides, 107 academic mentors and 3 volunteers, whereas the PG wing has 8 core team members and 75 volunteers.

Counselor and Psychiatrists' Sessions

Students typically meet the counselors in two modes – they sometimes approach the counselors of their own volition, or are referred to the CS by their friends, faculty members, psychiatrists or the doctors at the Health Centre. Students with academic difficulty are also encouraged to meet the counselors for advice. In the 2017-18 session, 1872 counselor sessions were held.

The psychiatrists typically visit the campus at least twice a month. In times of emergency, the student is directly sent to the psychiatrist's clinic, along with an attendant. All the activities related to a psychiatrist's visit are coordinated by the Counselling Service.



Financial Assistance

Through the Students Benevolence Fund (SBF), the Counselling Service provides financial assistance to needy students in the form of scholarships. This is available to financially needy stu-

dents who have been unable to acquire any other financial assistance from the institute. The SBF scholarship is Rs.1500 per month and given for 9 months. Apart from this, SBF Loans are also available to those who are in dire need of money.

Academic Assistance

Academic assistance is provided to students facing difficulty in coping with the academic load. The support exists both at an individual as well as at a group level and is free of cost.

- Remedial Classes: Remedial classes are organized by academic mentors (senior students) to help academically deficient students.
- Study Hours: For underperforming students, study hours are organized by academic mentors during the week before the examinations.
- Technical Terminology Classes: To help those students facing difficulty in understanding the English technical terms, the Technical Terminology Classes are organized during the beginning of the semester.

Support to Probation Students

The Counselling Service provides emotional as well as academic support to the students on academic probation/warning. This year, the students in AP/WR were allotted a guide from the operations or guidance team, whose responsibility was to look after his/her allotted counselee and also to act as a link between the student and the counselor. Individual counseling sessions are offered to improve the academic performance as well as to resolve emotional issues. A session for the first year students in probation/warning was conducted to motivate them to perform better. This had a positive impact on the students.

Orientation Programme

Each year, the Orientation Program is organized for the freshmen before the beginning of the new academic session in July to acquaint them with the facilities, services, personnel, rules and regulations of the institute, and to facilitate a smooth transition into life at the institute. A similar session is again organized by the PG team in December.

The core team members, student guides, student volunteers attached to the Counselling Service help the newcomers in this process. Gymkhana presentations, sessions with the counselors, group activities, and wing competitions were organized as part of the Orientation Program. To tackle the issue of substance abuse, psychiatrist Dr. Sanjay Mahendru was invited for a session on the 27 July 2017 to sensitize the students about the issue. There were talks by the doctors at the Health Center as well during the orientation program.

Skill Enhancement Workshops/Classes

English Conversation Classes: English Conversation Classes are organized during the semesters for the students who face difficulty in understanding and communicating in English. These classes are free of cost and are open to all the students.

Sessions on Other Broad Issues

- Explore your department
- Session on Study Techniques
- Intern Gyan
- ESO/SO awareness session

Student Placement

More than 250 companies participated in the Campus Recruitment Drive during 2017-18. Approximately 82% of the graduating batch (including UG and PG) were placed through Student Placement Office during the academic year 2017-18. Some of the major companies that took part in recruitment drive were Intel, Tata Motors, EXL Services, Goldman Sachs, Microsoft, Bank of America, Michelin, Exxon Mobil, Samsung, BlackRock, Michelin, UIDAI, Rubrik Inc., American Express, etc.

Students Placement at PG level

Approximately 80% of PG students graduating in the year 2017-18 were placed through Student Placement Office. Among the 563 PG students registered for placements this year, 449 were placed till date. Amongst the various programs, the MBA recorded the highest percentage of placements at 100% followed by M. Design at 92%, Dual Degree at 88%, M. Tech degree at 73% and M. Sc (2 yrs.) program at 70%.

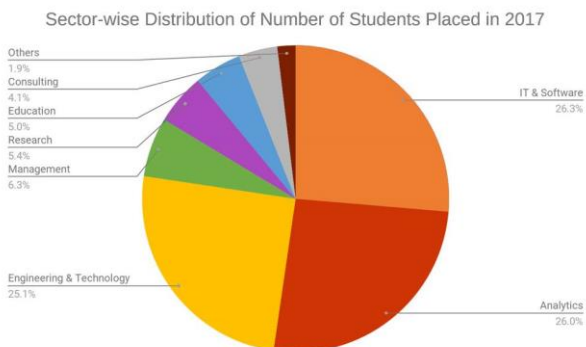

Students Placement at UG Level

Approximately 84% of the B. Tech and B.S. degree students were placed through SPO during the Campus Recruitment drive during 2017-18. Among the 419 UG students registered for

placements this year, 355 were placed till date. This includes 80 Pre-Placement Offers (accepted PPOs) received during internships facilitated by the Student Placement Office.

Unnat Bharat Abhiyan

Under Unnat Bharat Abhiyaan, a scheme funded by MHRD to uplift rural India, IIT Kanpur has adopted five surrounding villages - Hridayapur, Baikanthpur, Ishwariganj, Pratappur Hari and Saxupurva. The outreach activities aimed at the overall upliftment of the villages will focus on cleanliness, computer literacy, harnessing solar energy and using technology for better farming techniques. A survey was conducted to explore the needs and interests of the villagers. The results of the survey will be compiled in a report and then analyzed for on-ground work.



Most of the villagers have responded enthusiastically to the initiatives from IITK.

Epilogue

Dear degree recipients, on this memorable event of the fifty-first convocation, I congratulate and commend each one of you on your brilliant achievements and convey my best wishes to the entire class of 2018 graduating today. I also take this opportunity

to congratulate your proudparents and guardians for making you what youare today and encourage you to strive for excellence relentlessly. Now, that your journey towards the greater world begins, I would like to share some of my thoughts with you.

As an alumnus of IIT Kanpur, I myself had once enteredhumbly into this institute in quest of knowledge and walked through its glorious portals to the bigger world to seekmy destiny.The precious degree I obtained from this institute inspired me to face challenges in my professional career and achieve success. Today,I have come back to you as a leader of this institute with the message 'nihil ultra' -nothing is beyond the capability of humankind as long as you employ right effort in the right direction. I am confident your teachers/mentors of this institute have instilled enough wisdom, enough courage and enough ambition in you to achieve your dreams as my mentors did. With your acquired knowledge, passion, and determination, I am confident that you will continually strive tousher in a revolution of quality in both professional and social domains.

May God bless you with health, happiness, and peace. May you prove yourself a worthy son ordaughter of this great nation, may each one of you scale so high that we never tire ofextolling you and bask in your glory, and aboveall, may your unstinted effort turn victoriousat the culmination!

Books published

1. Fundamentals of Rocket Propulsion, D. P. Mishra (AE), CRC Press. 2017, ISBN: 9781498785358.
2. Adaptive Aeroservoelastic Control, Ashish Tewari (AE), Wiley, Chichester, U.K. 2016.
3. Chemical and Synthetic Approaches in Membrane Biology, Arun Shukla (BSBE), Springer, 2017, ISBN 978-1-4939-6835-0 (print) 978-1-4939-6836-7 (Online).
4. G-Protein Coupled Receptors, Part A, Methods in Cell Biology, Vol 142, Arun Shukla (BSBE), Academic Press, Elsevier 2017, ISBN 9780128133194
5. Metal semiconductor core-shell nanostructures for energy and environmental applications, Gupta R. K., Misra M. (CHE), Elsevier, (2017) 9780128124451; 9780323449229, 1-201.
6. Hybrid Polymer Composite Materials: Structure and Chemistry, Edited by V. K. Thakur, M. K. Thakur and R. K. Gupta (CHE), Woodhead Publishing, Elsevier, 2017, ISBN: 9780081007914.
7. Hybrid Polymer Composite Materials: Processing, Edited by V. K. Thakur, M. K. Thakur and R. K. Gupta (CHE), Woodhead Publishing, Elsevier, 2017, ISBN: 9780081007891.
8. Coulson and Richardson's Chemical Engineering (7th edition) Volume 1A: Fluid Flow: Fundamentals and Applications, R. P. Chhabra and V. Shankar (CHE), Elsevier, (2017).
9. Coulson and Richardson's Chemical Engineering (7th edition) Volume 1B: Heat and Mass Transfer: Fundamentals and Applications, R. P. Chhabra and V. Shankar (CHE), Elsevier, (2017).
10. Catalytic molten metals for the direct conversion of methane to hydrogen and separable carbon, co-authored by Dr. Vishal Agarwal (CHE).

11. Wireless Networking and Mobile Data Management, R. K. Ghosh (CSE), Springer, 2017, ISBN 978-981-10-3941-6.
12. Non-convex Optimization for Machine Learning, Purushottam Kar (CSE), Now publishers, 2017, ISBN: 978-1-68083-368-3 (Print) 978-1-68083-369-0 (Online).
13. Theorizing International Trade: An Indian Perspective, Edited by Mathur, S.K., Arora, R. and Singh, S. (Eco. Sc.) (2017), Palgrave Macmillan.
14. Urbanization in India: Issues and Challenges, Arun Kumar Sharma and Bhaskar Dutt Misra (HSS), Ane Books Pvt Ltd, New Delhi.
15. The Writer, the Reader and the State: Literary Censorship in India, Mini Chandran (HSS), Sage, (2017), New Delhi.
16. Eminent Indian Psychologists: 100 Years of Psychology in India, edited by Braj Bhushan (HSS), Sage Publications, (ISBN: 9789386446411).
17. Faith and Social Movements: Religious Reform in Contemporary India, Anindita Chakrabarti (HSS), Cambridge University Press, Cambridge, UK.
18. The Changing Language Roles and Linguistic Identities of the Kashmiri Speech Community, Dr. M. Ashraf Bhatt (HSS), supervised by A.K. Sharma and T. Ravichandran, Cambridge Scholars, Newcastle, UK.
19. Innovation, Incubation and Entrepreneurship: Case Studies from IIT Kanpur, Phani B. V. (IME), Khandekar S. (ME), Springer, ISBN: 978-981-10-3333-9 (Print) 978-981-10-3334-6 (Online), (2017).
20. Modeling and Simulations of Turbulent Combustion, Santanu De, Avinash K Agarwal, (ME), Springer, Singapore, 2018, ISBN: 978-981-10-7409-7.
21. Shapes and Dynamics of Granular Minor Plants, Ishan Sharma (ME), Springer International Publishing, (2017).

22. Modeling Transport Phenomena in Porous Media with Applications, Malay K. Das (ME), Springer, 2017, ISBN: 978-3-319-69864-9 (Print) 978-3-319-69866-3 (Online).
23. Fluid Mechanics and Fluid Power- Contemporary Research, A. K. Saha, D. Das, R. Srivastava, P.K. Panigrahi, K. Muralidhar (ME), Springer, (2017).
24. Pipe Inspection Robots for Structural Health and Condition Monitoring, co-authored by Bishakh Bhattacharya (ME), Springer.
25. Environmental Contaminants, Tarun Gupta, Avinash K Agarwal (ME), Rashmi A Agarwal, Nitin K Labhsetwar, Springer, Singapore, 2018, ISBN: 978-981-10-7332-8.
26. Air Pollution and Control, Nikhil Sharma, Avinash K Agarwal (ME), Peter Eastwood, Tarun Gupta, Akhilendra P Singh, Springer, Singapore, 2018, ISBN: 978-981-10-7184-3.
27. Coal and Biomass Gasification, Santanu De, Avinash K Agarwal (ME), V S Moholkar, Thallada Bhaskar, Springer, Singapore, 2018, ISBN: 978-981-10-7334-2.
28. Droplets and Sprays, Saptarshi Basu, Avinash K Agarwal (ME), Achintya Mukhopadhyay, Chetan Patel, Springer, Singapore, 2018, ISBN: 978-981-10-7448-6.
29. Advances in Internal Combustion Engine Research, 345 pages, Published by Springer, Singapore (2018), (Eds.) Dhananjay K Srivastava, Avinash K Agarwal (ME), Amitava Datta, Rakesh K Maurya (ISBN # 978-981-10-7574-2) DOI: 10.1007/978-981-10-7575-9.
30. Prospects of Alternative Transportation Fuels, Akhilendra P Singh, Avinash K Agarwal (ME), Rashmi A Agarwal, Atul Dhar, Mritunjay Kumar Shukla, Springer, Singapore, 2018, ISBN: 978-981-10-7517-9.
31. Environmental, Chemical and Medical Sensors, Shantanu Bhattacharya (ME), Avinash K Agarwal (ME), Nripen Chanda,

- Ashok Pandey, Ashis Kumar Sen, Springer, Singapore, 2018, ISBN: 978-981-10-7750-0.
32. Applications of Solar Energy, Himanshu Tyagi, Avinash K Agarwal (ME), Ashok Pandey, Prodyut R Chakraborty, Satvasheel Powar, Springer, Singapore, 2018, ISBN: 978-981-10-7205-5.
 33. Bioremediation: Applications for Environmental Protection and Management, Sunita J Varjani, Avinash K Agarwal (ME), Ashok Pandey, Edgard Ghansounou, Baskar Gurunathan, Springer, Singapore, 2018, ISBN: 978-981-10-7484-4.
 34. Applications Paradigms of Droplet and Spray Transport: Paradigms and Applications, Saptarshi Basu, Avinash K Agarwal (ME), Ashok Pandey, Achintya Mukhopadhyay, Chetan Patel, Springer, Singapore, 2018, ISBN: 978-981-10-7232-1.
 35. Proceedings of the 4th World Congress on Integrated Computational Materials Engineering (ICME 2017), P. Mason, C. R. Fisher, R. Glamm, M. V. Manuel, G. J. Schmitz, A. K. Singh (MSE), & A. Strachan (Eds.), Springer, 2017.

Fellowships

1. Dr. Abhishek (AE) has been chosen for the Abdul Kalam Technology Innovation Fellowship of INAE for three years.
2. Dr. S. Ganesh (BSBE) received Tata Innovation Fellowship (2017-2020) by Dept. of Biotechnology (DBT), Ministry of Science and Technology, Govt. of India.
3. Dr. Arun Shukla (BSBE) received CNR Rao Award for Excellence in Research by IIT Kanpur.
4. Dr. Yogesh M Joshi (CHE) has been elected Fellow of National Academy of Sciences, India.
5. Dr. Rahul Mangal (CHE) received Ramanujan Fellowship, SERB, Govt. Of India.

6. Dr. Vishal Agarwal (CHE) received Ramanujan Fellowship, SERB, Govt. Of India.
7. Dr. J N Moorthy, (CHM), has been elected Fellow of the Indian National Science Academy, New Delhi.
8. Dr. J. K. Bera, (CHM) has been elected Fellow of the Indian National Science Academy, New Delhi.
9. Dr. Amalendu Chandra (CHM) has been elected Fellow of The National Academy of Sciences, India.
10. Dr. Sankar P. Rath (CHM) has been elected Fellow of the National Academy of Sciences, India.
11. Dr. Sankar P. Rath (CHM) has been elected Fellow of the West Bengal Academy of Science & Technology.
12. Dr. Surender Baswana (CSE) received Humboldt Fellowship for Experienced Researchers from Humboldt Foundation of Germany.
13. Dr. Laxmidhar Behera (EE) has been elected Fellow of the Indian National Academy of Engineering (INAE).
14. Dr. Anindita Chakrabarti (HSS) has been elected a Senior Fellow, Humanities Centre for Advanced Studies (2016-2020) of Leipzig University.
15. Dr. Kumar Ravi Priya (HSS) received Fulbright-Nehru Academic and Professional Excellence Fellowship-Flex Award by USIEF.
16. Dr. RN Sengupta (IME) received DAAD Fellowship for Research Stays for University Academics and Scientists, 2017, Technische Universität Dresden, Germany.
17. Dr. Sameer Khandekar (ME) has been elected Fellow of Institution of Engineers (India).
18. Dr. Kantesh Balani (MSE) received Swarnajayanti Fellowship Award 2016-17 by Department of Science and Technology, Govt. of India.

19. Dr. Krishanu Biswas (MSE) has been elected Young Fellow of Global Young Academy (GYA), Germany.
20. Dr. A.K. Singh (MSE) received the Fellowship of the Indian Institute of Metals.
21. Dr. Sandeep Anand (EE), Dr. Joydeep Chakraborty (PHY), Dr. Somnath Jha (M&S) have been selected Associate(s) of the Indian Academy of Sciences, Bangalore.

Awards and Honors

1. Dr. Debopam Das (AE) has been awarded the 'Best Professor in Aerodynamics' in the subcategory: Education Leadership Award by Dewang Mehta National Education Awards.
2. Dr. Arun Shukla (BSBE) has been selected for the B.M. Birla Science Prize in Biology for the year 2016.
3. Dr. Arun Shukla (BSBE) has been selected for the Professor Umakant Sinha Memorial Award by the Indian Science Congress Association (ISCA).
4. Dr. Arun Shukla (BSBE) has been selected as European Molecular Biology Organization (EMBO) Young Investigator.
5. Dr. Arun Shukla (BSBE) has been selected co-recipient of CDRI Award for Excellence in Drug Research.
6. Dr. Sachchida N Tripathi (CE) has been chosen for felicitation by the Government of Uttar Pradesh.
7. Dr. Yogesh M Joshi (CHE) received RPG Life Sciences M. M. Sharma Gold Medal by Indian Institute of Chemical Engineers.
8. Dr. Ashutosh Sharma (CHE) was honored with the UNESCO Medal 2017 for contributions to and development of nanosciences and nanotechnology.
9. Prof. Ashutosh Sharma (CHE) has been honored with the H. K. Firodia Vijnan Bhushan Award 2017 for his pioneering and highly interdisciplinary work in nanotechnology and areas of health, energy and environment.

10. Dr. Vinod K Singh (CHM) has been chosen for felicitation by the Government of Uttar Pradesh.
11. Dr. Sandeep Verma (CHM) has been chosen for felicitation by the Government of Uttar Pradesh.
12. Dr. K. Srihari (CHM) has been awarded the prestigious INSA Teachers Award (2017).
13. Dr. Jitendra K. Bera (CHM) has been selected for the C. N. R. Rao National Prize in Chemical Sciences 2018.
14. Dr. Sandeep Verma (CHM) has been selected for the MRSI-ICSC Superconductivity & Materials Science Annual Prize by the Material Research Society of India for the year 2018.
15. Dr. Sandeep Verma (CHM) received Silver Medal by The Chemical Research Society of India.
16. Dr. Pratik Sen (CHM) has been awarded the Young Faculty Research Fellowship by the Ministry of Electronics and Information Technology, Govt. of India.
17. Dr. Nishanth N. Nair (CHM) received Distinguished Lecture-ship Award by The Chemical Society of Japan.
18. Dr. Manindra Agarwal (CSE) has been chosen for felicitation by the Government of Uttar Pradesh.
19. Dr. T.V. Prabhakar (CSE) received Teaching Innovator Award-2016 by MHRD, New Delhi.
20. Dr. T.V. Prabhakar (CSE) received SKOCH GOLD Award in the category of "Technology for Growth" for the AgMOOC project.
21. Dr. Biswabandan Panda (CSE) received INSPIRE Faculty Award by DST.
22. Dr. Amey Karkare (CSE), Dr. Purushottam Kar (CSE) and Dr. T V Prabhakar (CSE) received Best faculty of the year in the category of Evangelizing and Contributing to Spread of knowledge across several Institutions; Innovative Application of Technology Tools in Teaching/Learning;

- Authoring Books On Contemporary Subjects respectively by the Computer Society of India, Mumbai Chapter.
23. Dr. Surendra Baswana (CSE) received Distinguished Teacher Award 2017 by Indian Institute Technology Kanpur.
 24. Dr. A.K. Chaturvedi (EE) has been awarded the prestigious INSA Teachers Award (2017).
 25. Dr. Sandeep Anand (EE) has been selected for the INAE Young Engineer Award 2017.
 26. Dr. Ketan Rajawat (EE) received INSA Medal for Young Scientist by INSA.
 27. Dr. K. Vasudevan (EE) has been awarded the Top Reviewers for Multidisciplinary by PUBLONS.
 28. Dr. Santanu Misra (ES) has been awarded the prestigious Dr. K.R. Gupta Gold Medal by the Council of the Geological Society of India.
 29. Dr. Shib Sankar Ganguly (ES) received the Young Scientist Award by the Ministry of Mines, Govt. of India.
 30. Dr. Ritwij Bhowmik (HSS) received “Young Scientist in Visual Culture” for the year 2017, Venue International Research Awards, Venus International Foundation, awarded at the 3rd Annual Research Meet-ARM 2017 in Chennai, 11th November 2017.
 31. Dr. RRK Sharma (IME) has been selected as one of the Top Ten Knowledge Producers in India for the Academic Year 2017-18 by Faculty Research Award Career 360, 2017-18.
 32. Dr. Debasis Kundu (M&S) received P.C. Mahalanobis award by Operation Research Society of India.
 33. Dr. Avinash Kr. Agarwal (ME) received the 6th edition of the India Research Excellence- Citation Awards by Clarivate Analytics.
 34. Dr. Bhaskar Dasgupta (ME) received the Mechanism and Machine Theory Award for Excellence.

35. Dr. Gautam Biswas (ME) (presently Director, IIT Guwahati) has been awarded Honorary Doctorate (Honoris Causa) by NIT Agartala.
36. Dr. Sudhanshu Shekhar Singh (MSE) received 2018 SMD JOM Best Paper Award by The Minerals, Metals & Materials Society (TMS), USA.
37. Dr. Sudhanshu Shekhar Singh (MSE) received IEI Young Engineers Award by The Institute of Engineers (India).
38. Dr. Sudhanshu Shekhar Singh (MSE) received Young Metallurgist of the Year 2017 Award by The Indian Institute of Metals (IIM), India.
39. Dr. Ashish Garg (MSE) received Newton Prize Award for DST-RCUK APEX Project by UK National Commission for UNESCO.
40. Dr. Kallol Mondal (MSE) received Mascot National Award by Electrochemical Society of India.
41. Dr. Krishanu Biswas (MSE) received Metallurgist of the Year, 2017 in Metal Sciences Category by Ministry of Steels, Government of India.
42. Dr. Anish Upadhyaya (MSE) received Distinguished Teacher Award 2017 by Indian Institute Technology Kanpur.
43. Dr. Amit Agarwal (PHY) has been awarded the "IPA N. S. Satya Murthy Memorial Award in Physics-2016" of the Indian Physics Association.
44. Dr. H.C. Verma (PHY) has been awarded the Maulana Abdul Kalam Azad Shiksha Puraskar-2017.
45. Dr. Mahendra Verma (PHY) has been awarded the "Dr. APJ Abdul Kalam Cray HPC award by Cray Computers.
46. Dr. Indranil Manna (Former Director) has been conferred the D.Sc. Degree (Honoris Causa) of the University of Kalyani (WB) during the University convocation (7th September 2017).

Appointments

1. Dr. Debabrata Goswami (CHM), Member of the Scientific Panel on Stamping and Analysis, by Food Safety and Standards Authority of India (FSSAI).
2. Dr. J.N. Moorthy (CHM), Member, Commission of Crystallographic Teaching, by The International Union of Crystallographic (IUCr), 2018-2020.
3. Dr. Manindra Agrawal and Dr. Sandeep Shukla (CSE) were invited to serve on a special committee on cybersecurity of UIDAI information systems.
4. Dr. Sandeep Shukla (CSE) served on two special committees of the RBI to consider cybersecurity of mobile payments and online banking.
5. Prof. Rajiv Shekhar (MSE) is appointed the Director of IIT (ISM) Dhanbad.

Editorships/Membership

1. Dr. C. Venkatesan (AE), Associate Editor, Journal of Intelligent Unmanned Systems, Emerald Publishing.
2. Dr. A.K. Ghosh (AE), Member of National Advisory Board of DRDO Young Scientist Center.
3. Dr. Arun Shukla (BSBE) has been invited to join the Editorial Board of Cellular Signaling, Elsevier.
4. Dr. Arun Shukla (BSBE) has been invited to join the Editorial Board of Chemical Biology & Drug Design, Wiley.
5. Dr. Jayandharan Rao (BSBE) selected as an invited member of the Hematology and Immunology Gene and Cell therapy Committee for the period of 2017-2020.
6. Dr. Yogesh M Joshi (CHE), Member of Editorial Advisory Board, Langmuir, American Chemical Society.

7. Dr. Raju Kumar Gupta (CHE), Member of Editorial Advisory Board, Molecular Systems Design & Engineering, Royal Society of Chemistry.
8. Dr. Jayant Singh (CHE) has been invited to join the Editorial Board of ACS Omega.
9. Dr. R N Mukherjee (CHM) has been invited as a Guest Co-Editor of the ACS journal Inorganic Chemistry for Reactivity of Metal Complexes with Ligand-Centered Radicals.
10. Dr. Jitendra K Bera (CHM) has been invited to join as an Associate Editor of Applied Organometallic Chemistry, AOC, Wiley Interscience.
11. Dr. S.P. Rath (CHM), Member of Editorial Advisory Board, Current Inorganic Chemistry, Bentham Science.
12. Dr. J.N. Moorthy (CHM), Member of Editorial Board, Journal of Chemical Sciences, Springer.
13. Dr. Basker Sundararaju (CHM), Member of Early Career Advisory Board, ACS Catalysis, American Chemical Society.
14. Dr. Sandeep Shukla (CSE), Associate Editor, ACM Transactions on Cyber Physical Systems, ACM.
15. Dr. Sandeep Shukla (CSE), Book Series Editor, River Publishers Series, Information Science and Technology, River Publishers, Denmark.
16. Dr. Yogesh Singh Chauhan (EE) has been invited to serve as an editor for "Device and Process Modeling", IEEE Transactions on Electron Devices.
17. Dr. Ketan Rajawat (EE), Associate Editor, IEEE Communication Letters, IEEE.
18. Dr. Rajiv Sinha (ES), Member of Editorial Board, Earth Surface Processes & Landforms, Wiley.
19. Dr. Rajiv Sinha (ES), Member of Editorial Board, Current Science, Indian Academy of Science.

20. Dr. Debajyoti Paul (ES), Member of Editorial Board, Chemical Geology, Elsevier.
21. Dr. Kumar Ravi Priya (HSS), Associate Editor, Psychological Studies, Springer.
22. Dr. Malay Banerjee (M&S), Associate Editor, Mathematical Modeling of Natural Phenomena, EDP Sciences.
23. Dr. Anindya Chatterjee (ME), Editorial Board Member, International Journal of Mechanical Sciences, Elsevier.
24. Dr. Avinash Kumar Agarwal (ME), Editor-in-Chief, Journal of Energy and Environmental Sustainability, International Society for Energy, Environment and Sustainability.
25. Dr. Bishakh Bhattacharya (ME), Editorial Board Member, Journal of Low Frequency Noise and Vibration Control, SAGE Publishing.
26. Dr. K. Muralidhar (ME), Editor-in-Chief, Journal of Flow Visualization and Image Processing, Begell House.
27. Dr. P. S. Ghoshdastidar (ME), Editorial Board Member, Engineering Science and Technology, an International Journal, Elsevier.
28. Dr. Sameer Khandekar (ME), Editorial Board Member, Interfacial Phenomena and Heat Transfer, Begell House.
29. Dr. Sumit Basu (ME), Associate Editor, Sadhana, Indian Academy of Sciences.
30. Dr. Kantesh Balani (MSE), Editor in Chief, Nano materials and Energy, ICE Publication.
31. Dr. Kantesh Balani (MSE), Guest Editor, Journal of Thermal Spray Technology, International Thermal Spray Conference ITSC 2018 special issue), Springer.
32. Dr. Krishanu Biswas (MSE), Guest Editor, J. Materials Research for Special Issue on Nanostructured High Entropy Alloys: Processing Challenges and Properties, Materials Research Society, USA.

33. Dr. Rajdip Mukherjee (MSE) has been invited to co-edit “Phase-Field Methods for Pattern-Formation” by Journal of Indian Institute of Science.
34. Dr. Subhajit Dutta (M&S) is elected Member of the International Statistical Institute, The Netherlands.
35. Dr. Debashish Chowdhury (PHY) has been elected and appointed a member of the “C6 Commission: Biological Physics” by the 29th General Assembly of the International Union of Pure and Applied Physics (IUPAP).

Students' Awards

1. Mr. Karthik S. (AE), Rahul Ramanujam (AE), Ramdas (AE), Diksha Aggarwal(AE), Sakshi Gupta (AE), Avinash Shet (AE), Vishesh Kumar Singh(AE), and Naba Kishore Routray (AE) have received third prize in the graduate category of 34th Annual Student Design Competition by American Helicopter Society (AHS) (August 2017) for designing a High Efficiency Dissimilar Coaxial Helicopter design called “Vibhram”.
2. Mr. Sagar Setu (AE), Mr. Nidhish Raj (AE) and Mr.Karthik. S. (AE) have won the first stage of "The Unmanned Aerial Systems Flight and Payload Challenge" organized by National Institute of Standards and Technology (US Department of Commerce) and Public Safety Communications Innovation Accelerator (USA).
3. Mr. Sourav Sinha (AE) won the prestigious Vertical Flight Foundation (of the American Helicopter Society) Scholarship for 2018 in UG category for his work on autopilot development for multicopter convertiplane for Urban Mobility (Air Taxi system) and aerial logistics.

4. Mr. Yonas Gebre (AE) won the best poster award at International Workshop on Sustainable Energy, Power and Propulsion (ISEPP2018) for his innovative work on the high efficiency vertical axis wind turbine.
5. Ms. Ritika Tiwari (BSBE) has been awarded the Shastri Research Student Fellowship (SRSF)-Doctoral award for the year 2017-18 for 13 weeks to undertake a research project on 'Role of SPINK1 in neuroendocrine transdifferentiation in prostate cancer' in Canada.
6. Ms. Punita Kumari (BSBE) was selected a co-recipient of the Sun Pharma Science Scholar Award 2017 in the Bio-Medical Sciences category.
7. Ms. Punita Kumari (BSBE) has received the first prize in the Young Scientists Oral Presentation category at the 86thConference of Society of Biological Chemists held in JNU during November 16th to 19th 2017.
8. Mr. Burra Gunasekhar (BSBE) has been elected the Chair for "Gordon Research Seminar (GRS) on CAG Triplet Repeat Disorders" to be held in 2019-Italy.
9. Mr. Parvaiz A. Shiekh (BSBE) was awarded Torrent ISHR Young Investigator Award at a conference on Cardiovascular Research Convergence 2017: A scientific forum for exchanging of research views between clinicians and basic scientists, held on 12th August, 2017 at the THSTI (Translational Health Science and Technology Institute) Faridabad, jointly organised by THSTI (Faridabad) and AIIMS (New Delhi) in collaboration with International Society for Heart Research (ISHR, Indian chapter).
10. Mr. JacklinJেকেNilling (CE) and Mr. Akshat Verma (CE) won 4th position in the 7th International Groundwater Conference (IGWC-2017) held at ICAR-NASC Complex, New Delhi (De-

- ember 11-13, 2017), organised jointly by NIH, Roorkee, Central Ground Water Board, India, Texas A&M, and AGGS. Poster Title: "Geochemical Analysis of Arsenic Speciation in Groundwater".
11. Ms. Khushboo Suman (CHE), Mr. Indresh Chaudhary (CHE) and Mr. Mohammad Khalid (CHE) have been chosen for the best poster award at the CompFlu 2017 symposium (Symposium on Complex fluids) held at IIT Madras.
 12. Ms. Shweta Dixit (CHE) received the Best Paper Award under session of Waste Water Treatment, in 70th Annual Session of Indian Institute of Chemical Engineers (CHEMCON-2017) on Versatility of Chemical Engineering to Meet Societal Challenges, organized by Haldia Regional Center in association with Department of Chemical Engineering, HIT, Haldia, (December 27-30, 2017). Paper titled: "Development of a Recombinant Bacterium for Mineralization of Hazardous Sulphonated Aromatic Amines from Industrial Wastewater".
 13. Mr. Saikat Das (CHM) received Cash Prize Award in Organic Chemistry Symposium held at IIT Kanpur for the paper titled: "Enantiospecific Total Syntheses of Carbazole Alkaloids Murrayamines-O,P and Marine Natural Products Hapalindole-H, 12-epi-Hapalindole-UName:".
 14. Mr. Hilal Ahmad Pal (CHM) received Cash Prize Award in Organic Chemistry Symposium held at IIT Kanpur for the paper titled: "Self-assembling soft structures for intracellular NO release and promotion of neurite outgrowth".
 15. Mr. Bapan Saha (CHM) received Book Prize Award in Organic Chemistry Symposium held at IIT Kanpur for the title: "Supramolecular Chirogenesis: Chirality Induction, Inversion and Amplification".
 16. Ms. Deepti Kalsi (CHM) received Book Prize Award in Organic Chemistry Symposium held at IIT Kanpur for the paper titled

- “Co (III)-Catalyzed Isonitrile Insertion/Acyl-Group Migration Between C-H and N-H Bonds of Arylamides” respectively.
17. Mr. Prithwidip Saha (CHM) has received the IUVSTA-Elsevier Student Award for his presentation at 33rd European Conference on Surface Science (ECOSS) held at Szeged, Hungary during 27th Aug. to 1st September 2017.
 18. Ms. Chetna Yadav (CHM) received the best poster award in International Union Crystallography Congress held at Hyderabad (August 21-28, 2017) for her work titled "Influence of Sterics on the Self-Assembly of Sterically-Hindered Arylsulfonamides".
 19. Mr. Sagarmoy Mondal (CHM) has been awarded the Best Poster Award in an International Symposium -CPMD 2017, held in Tsukuba, Japan (Oct 18-20, 2017) for his poster titled “Ab Initio MD Simulations with Hybrid Functionals: Implementation and Application”. This work was carried together with a BS-MS student, Ms. Jayashrita Debnath (CHM) as a part of her MS Project.
 20. A recent paper of Mr. Vijay Kumar Maska (CHM) titled "Photochromic 2D MetalOrganic Framework Nanosheets (MONs): Design, Synthesis, and Functional MON-Ormosil Composite" is published in the journal, CHEM. The work demonstrates that 2-dimensional metal-organic nanosheets (MONs) constructed from photochromic building blocks can be used for the desired optical properties in photochromic polymers. This research will have many applications notably in ophthalmic lenses. CHEM is a prestigious journal published by the Cell Press.
 21. Mr. Vipin Mishra (CHM) has received the best paper presentation award for the work entitled "Two dimensional materi-

- als for electronic applications" at the International Conference on Thin Film (ICTF-17), held during Nov 13-17, 2017, at CSIR-NPL, New Delhi, India.
22. Mr.Mrigank Singh Verma (CHM) has received 'RSC Best Poster Award' for his presentation at the National Symposium on Convergence of Chemistry and Materials (CCM 2017), held at BITS Pilani, Hyderabad Campus, during Dec 21-22, 2017.
 23. Mr. Vishwesh Jatala (CSE) for his poster titled "GREENER: A Tool for Improving Energy Efficiency of GPU Register File" has been selected for the Best Poster Award at the 24th IEEE International Conference on High Performance Computing, Data, and Analytics, Student Research Symposium (HiPC, SRS), held during Dec 18-21, 2017 in Jaipur, India.
 24. Vishwesh Jatala (CSE), Ph.D. student received the "Best Poster Award" at the 24th IEEE International Conference on High Performance Computing, Data, and Analytics, Student Research Symposium (HiPC, SRS), for his work titled "GREENER: A Tool for Improving Energy Efficiency of GPU Register File".
 25. Umair Z. Ahmed (CSE) won the best poster award for the work titled "Automated Example Hint Generation for Syntax Errors in Student Programming Assignments" during his internship at IBM Bangalore.
 26. Mr. Nayan Deshmukh, Mr. Snehil Verma, Mr. Prakhar Agrawal (CSE) won the second prize for their outstanding performance at the International symposium on Computer Architecture.
 27. Ms. Ritika Singh (Design) has been awarded the Gandhian Young Technological Innovation Award 2018.
 28. Mr. C Vimal (Design) has been awarded the Gandhian Young Technological Innovation Award 2018 for his thesis project

- titled TULO- An automated mandibular advancement device for the treatment of sleep apnea.
29. Mr. Karthik. P B (Design) has won The Red Dot Design Award for 2017 hosted by the Design ZentrumNordrheinWestfalen in Essen, Germany.
 30. Mr. Ashish Mohandas (Design) has become the first Indian National to receive the 'James Dyson Award' by the James Dyson Foundation for his work titled "Design and development of an efficient low-cost retrofit patient transfer stretcher".
 31. Mr. Gajendra Raikwar (Design) received the Design Hackathon Award hosted by Adani group.
 32. Ms. Soumya Sahoo (EE), VandanaPawreya and Apoorva Shukla (CE) received an award titled "Pratibha: An Eaton Excellence Award 2017-2018" by Eaton India.
 33. IITK-TCS team reached to the podium finish at the Amazon Robotics Challenge 2017, Nagoya, Japan. (EE).
 34. Mr. Nachiketa Deshmukh, Abhinav Arya and Avinash Maguluri (EE) have been selected the University Challenge winners of the DST-Lockheed Martin-Tata Trusts India Innovation Growth Programme (IIGP) 2.0 for 2017. Their innovation is in the area of Solar PV Inverters.
 35. Ms. Asha Sharma (EE) has been granted the 2017 IEEE DEIS (Dielectrics and Insulation Society) Fellowship, for her project entitled "Modelling of interfaces in Nano-dielectrics using Electron Force Microscopy".
 36. Dr. Sinnu Susan Thomas (EE) has received the Gandhian Young Technological Innovation (GYTI) 2018 Award from the Society for Research and Initiatives for Sustainable Technologies and Institutions (SRISTI).
 37. Mr. S. Vinoth Kumar (EE) received 'Honors Award' for his work entry titled "Design of a Two Port Dual-Polarized Trefoil

- Torus Knot Antenna using Characteristic Mode Analysis” in 2017 FEKO Design Competition.
38. Mr. Girish Pahwa (EE), for “Energy-Delay Tradeoffs in Negative Capacitance FinFET based CMOS Circuits” has been selected for the best paper award in IEEE International Conference on Emerging Electronics (ICEE), Mumbai, India, Dec. 2016.
 39. Dr. Kushmanda Saurav (EE) has been awarded the best thesis for his thesis entitled “Studies On Multi-band Linearly and Circularly Polarized Printed Antennas For Wireless Communication Systems” in the Electronics track of the Ph.D. symposium organized by IEEE Uttar Pradesh Section International Conference on Electrical, Computer and Electronics (IEEE UPCON 2017) held at GLA University, Mathura (26-28 October 2017).
 40. A paper titled "A Polarization-Insensitive Frequency Selective Radome with Wideband Absorption" authored by Mr. Ritesh Pandey (EE), Saptarshi Ghosh (EE), Harsh Sheokand (EE), Mondeep Saikia (EE) has received the Best Paper Award in "Antenna and Microwave" track in "4th IEEE UP Section Conference on Electrical, Computer and Electronics (IEEE UPCON)" organized by IEEE UP Section and hosted by GLA University Mathura.
 41. Dr. Saptarshi Ghosh (EE) has been selected as one of the Young Scientist Awardees in 2nd URSI Atlantic Radio Science Meeting (AT-RASC) held at Gran Canaria, Spain during May 27- June 2, 2018.
 42. Mr. Priyank Rastogi (EE) has been awarded for the Best Oral Presentation under Advances in Electron Devices track in IEEE International Conference on Electronics, Computing and Communication Technologies (IEEE-CONECCT 2018) organised by IEEE Bangalore for the paper on "Diameter

Scaling in III-V Gate-All-Around Transistor for Different Cross-Sections".

43. Mr. Ankit Yadav (EE), for his paper titled "Modular Multi-level Converter Topologies: Present Status and Key Challenges" has been selected for the best paper award in IEEE UP section International Conference on Electrical, Computer and Electronics (IEEE UPCON 2017) held at GLA University, Mathura (26-28 October 2017).
44. Mr. S. Vinoth Kumar (EE) has received the best paper award for his paper titled "Circularly Polarized 3D Printed Knot Antenna with Sequential-Phase Feed" at 2017 IEEE International Conference on Antenna Innovations & Modern Technologies for Ground, Aircraft and Satellite Applications (iAIM 2017) at Bangalore, India on 24-26 November 2017.
45. The paper titled "Differential Quasi Self-Complimentary (QSC) Ultra-Wideband (UWB) MIMO Antenna" authored by Ms. Yashika Sharma (EE), Mr. Debdeep Sarkar (EE) and Mr. Kushmanda Saurav (EE) has been selected for NNSSRK Best Female Student Paper Award in "IEEE International Conference on Antenna Innovations and Modern Technologies (IEEE iAIM)" organized by IEEE Bangalore section.
46. Mr. Debdeep Sarkar (EE), for his paper titled "A Compact Two-Port MIMO Antenna with Enhanced Isolation using SRR-loaded Slot-loop" has received the second prize in the student paper competition (SPC) in "IEEE Applied Electromagnetics Conference (IEEE AEMC)", organized by IEEE Kolkata section in MIT Aurangabad.
47. Mr. Adarsh Patel (EE) has been selected for Innovative Student Projects Award 2017 by Indian National Academy of Engineering (INAE).

48. Mr. Suraj Srivastava and Ms. Saumya Dwivedi (EE) have been selected for the Qualcomm Innovation Fellowship (QInF) 2018-2019 for an innovative idea entitled "Sparse Signal Processing for 5G mm Wave MIMO Technology."
49. Ms. Seema Kumari (ES) has been selected DAAD fellow to pursue one year research work at University of Münster, Germany.
50. Ms. Sohini Bhattacharjee (ES) has been selected DAAD fellow to pursue one year research work at University of Potsdam, Germany.
51. Dipro Sarkar's (ES) Ph.D. work featured in a film "Mighty Rivers" broadcasted on Animal Planet on 8th April 2018.
52. Mr. Gaurav Seth (IME) has received Best Student Paper Award in 24th IAMB Conference, organized in collaboration with University of Wollongong, Dubai (October 9-11, 2017) for his paper titled "Does Global Capital Adequacy Regulation Hamper Growth of Bank Credit? Evidence from Indian Banks".
53. Mr. Vinayak A. Drave (IME) has published a conceptual paper on "Strategy and Supply Chain Structure of E-Tailers in India". After extensive Data collection and analysis the work got recognized by the Retailers association of India and published as a cover story (The changing interplay of Strategy , supply chain & Retail) in their quarterly magazine Storai (Vol 9 | Issue 3; March_April 2018).
54. MrSahil Kalra (ME) has been awarded excellent paper award in the 11th International Symposium at IPS, Waseda University, Japan for the paper "Intelligent RF Radiation Pattern Control by Reconfigurable Space Antenna".
55. Mr. Sanjay Kumar (ME) has won Merit Award for the IFMBE sponsored Young Investigator Award 2017 at the 10th Asian-

Pacific Conference on Medical and Bio-Engineering held at Penang Malaysia.

56. Mr. Ram Krishna Shah (ME) and Md. Asfer (ME) received the Best Poster Award at the 24th National, and 2nd International ISHMT-ASTFE Heat and Mass Transfer Conference (IHMTTC-2017) held at BITS-Pilani, Hyderabad Campus, (December 27-30, 2017) for the paper titled: "Control And Manipulation of Air - Ferrofluid Taylor Bubble Flow in a Magneto-Fluidic System".
57. Mr. Vikram Soni (ME) has received the Best Student Paper Award in "12th IIR Conference on Phase Change Material and Slurries for Refrigeration and Air Conditioning" for the paper titled "Behaviour of Phase Change Material during Discharge Stage in a Thermal Energy Storage System: An Experimental and Numerical Study".
58. Mr. Puneet Jindal (ME) has won the Best Poster Award in the workshop on 'Battery Technologies and Electric Mobility' organized by HPCL R&D Centre, Bangalore for the poster titled "Thermal Behaviour of Li-ion Batteries at High Discharge Rates."
59. Mr. Sankalp Verma (MSE) received the best poster award at International conference for advances in polymer science and technology, organized by Asian Polymer Association at New Delhi (23rd-25th November 2017).
60. Mr. Prvan Kumar Katiyar (MSE), for his poster titled "Corrosion behavior of newly developed TMT steel rebars" has been selected for the Best Poster Award in International Conference on Advanced Materials and Processes ADMAT 2017, SkyMat held during December 14-16, 2017 at Thiruvananthapuram, India.
61. Dr. Md. Faisal (MSE), received Hydrogen Energy and Advanced Materials (HEAM) Young Scientist Award 2018 along

- with a cash prize of Rs. 20,000 at University of Kerala by Indian Association of HEAM, funded by ONGC at Trivandrum, India, Mar. 5-6, 2018.
62. Ms. Khushubo Devi (MSE) has been selected for an internship from NIMS, Japan to work with Dr. Alok Singh.
 63. Mr. Nirmal Kumar (MSE) has got funding from SERB/DST to attend the International Conference on Rapidly Quenched and Metastable Materials (RQ16) Leoben, Austria.
 64. Mr. Prabhat K. Rai (MSE), 'Corrosion and wear behavior of harmonic structured SUS304L austenitic stainless steel' has been selected for the 'Best Poster Award' in '13th International Conference on Advanced Materials and Nanotechnology' held during October 26-28, 2017 in Osaka, Japan.
 65. H. S. Maharana (MSE), chosen for the Best poster award for the paper: "Electrophoretic Deposition of Cu-RGO Composite Coatings and its High Temperature Oxidation Resistance" authored by H. S. Maharana, A. Basu, K. Mondal, ICAMP ADMAT-SkyMat, Thiruvananthapuram, 14-16 Dec 2017.
 66. Mr. Pravan Kumar Katiyar (MSE), Best poster award for the paper: "Corrosion behaviour of Newly Developed TMT Steel Rebars" authored by Prvan Kumar Katiyar, S. Misra and K. Mondal, ICAMP ADMAT-SkyMat, Thiruvananthapuram, 14-16 December 2017.
 67. Ms. Semanti Mukhopadhyay (MSE) has been selected "Gold Award winner" ASM India - FluidthermMasters Award for her distinguished Master's research in the area of Materials Science and Engineering.
 68. Ms. Ambreen Nisar (MSE) has been selected "Silver Award winner" ASM India - Pradeep Metals Ph.D. Award for her distinguished Doctoral research in the area of Materials Science and Engineering.

69. Mr. Krashnavtar (MSE) has been selected for Dr. A K Bose Gold Medal, 2017 from the Indian Institute of Metals (IIM).
70. Mr. Arjak Bhattacharjee (MSE) has won the Best Poster Award for his poster entitled, "Crystal Chemistry of Transition Metal Doped Apatites and Their Potential as Antibacterial Agent" in NMD-ATM 2017 conference, organized by Indian Institute of Metals during 11th - 14th November in Goa.
71. Mr. Prabhat Kumar Rai (MSE) has been selected for the Best Poster Award in '13th International Conference on Advanced Materials, and Nanotechnology' held during October 26-28, 2017 in Osaka, Japan for his poster titled 'Corrosion and wear behavior of harmonic structured SUS304L austenitic stainless steel'.
72. Mr. Sourav Biswas (PHY), for his poster presentation on dynamic hysteresis in micro-SQUID has received the best poster award at the conference, Recent Trend in Condensed Matter Physics, held at Kolkata during Oct 31-Nov 3.
73. Mr. Anuj Ram Baitha (PHY), for his work titled "Radiation Belts and Particle Diffusion in a Plasma Confined by a Dipole Magnet" has received the Best oral presentation award (session: Plasma Diagnostics) in 32nd National Symposium on Plasma Science and Technology (PLASMA 2017), jointly organized by the Plasma Science Society of India (PSSI) and the Institute for Plasma Research (IPR), Gandhinagar (Gujarat) during November 7-10, 2017.
74. Ms. Kalyani Barman (PHY), for her poster titled "Optical Emission Spectroscopy and Electrical Modelling of Atmospheric Pressure Plasma Jets" has received Poster presentation award (session: Basic Plasma) in 32nd National Symposium on Plasma Science and Technology (PLASMA 2017), jointly organized by the Plasma Science Society of

- India (PSSI) and the Institute for Plasma Research (IPR), Gandhinagar (Gujarat) during November 7-10, 2017.
75. Ms. Kavita Rathore (PHY), for her poster titled "Application Of Fractal Dimension for the Study of Tomographic Images of a Microwave Induced Compact Plasma" has received Poster presentation award (session: Plasma Diagnostics) in 32nd National Symposium on Plasma Science and Technology (PLASMA 2017), jointly organized by the Plasma Science Society of India (PSSI) and the Institute for Plasma Research (IPR), Gandhinagar (Gujarat) during November 7-10, 2017.
 76. Ms. Meenaxi Sharma (PHY), for her poster titled "Effect of oil viscosity on sinking behavior of aqueous drops on lubricating fluid based slippery surfaces" has received the best poster award during 'COMPFLU 2017', held at IIT Madras during Dec 18 - Dec 20.
 77. Mr. Anil Kumar Singh (PHY) received the best poster award in the Annual Meeting on Physics of Strongly Correlated Electron Systems (PSCES), held at IIT Mandi (2-4 April 2018). The Title of his poster was "Role of Charge-State of Interface Defects on Electronic Inhomogeneity Evolution with Gate Voltage in Graphene".
 78. Mr. Ankit Kumar (PHY) and Mr. Biplab Bag received the best poster award in 62nd DAE Solid State Physics Symposium held at BARC, Mumbai (December 26-30,2017) for the poster titled: "Interplay of Superconductivity and Magnetic Fluctuations in Single Crystals of BaFe₂-xCoxAs₂".

Major Projects sanctioned

1. Nuclear Specific Delivery Of Anticancer Drug Via Ligand-Free PDMS Nanoparticles (DBT)

2. Climbing with support: Scaling volcano in electrocatalytic oxygen-evolution, chlorine-evolution and CO_2 reduction reactions (SERB)
3. Functional Characterization of Metabolism Related Genes (MRGs) with restricted expression in the developing vertebrate nervous system (DBT)
4. Effect of crystallographic texture on fracture behaviour of titanium and T16A14V using digital image correlation and electron backscatter diffraction (SERB)
5. Optical-Waveguide sensor for accurate detection of bio-contaminant in drinking water (SERB)
6. Nanohybrids for Hydrogen Storage (SERB)
7. Modeling Diheme Enzyme MauG: Understanding Nature's Design, Structure-Function Correlation and Application (SERB)
8. Dust or Soot? Tracing the Primary Drivers of Increased Glacial Melt of the Himalayan Glaciers (DST)
9. Modeling and imaging of gas hydrate reservoirs using integrated techniques (ONGC)
10. Compact Plasmon-based Bio-sensor and Imager (DST)
11. (Big) Biotechnology Ignition Grant (BIRAC)
12. PPP Mode Industry Projects (KIS)
13. Development of gas sensors for detection of adulteration and milk spoilage (KIS)
14. Design, Fabrication, and Characterization of Nanoparticle-based Photonic Elements (SERB)
15. Delineation of shallow subsurface morphotectonics below the central seismic gap-Himalaya using an integration of passive and controlled source seismology (SERB)
16. Development Of NASICON framework Cathode for All-Solid-State Na-ion Battery (SERB)
17. Modeling and imaging of Gas Hydrates reservoirs using integrated techniques (ONGC)

18. Micro-mechanisms of Deformation and Development of Processing Map for Novel Single and Multiphase High Entropy Alloys (SERB)
19. Development Of in-Situ contactless thermometer and viscometer through spatiotemporal control at nano-scale dimension to unravel the dynamics of complex system: vibrating molecules, colloidal clusters and multiple phases (SERB)
20. Explaining the puzzling experimental observations of polymer dynamics in solutions (SERB)
21. Development Of Background Oriented Schlieren (BOS) Technique For Density Measurement And Visualization In Buoyant Plumes (BARC)
22. Modeling of mechanical properties of AHSS steels using advanced characterization tools (TCS)
23. Human-Driven Full-Size 4WS4WD Electric Vehicle (SERB)
24. Micro-SQUID magnetometry of nano-scale magnetic structures (IFCPAR)
25. Learning Robotic Motor Skills, Visual Control and Perception for Warehouse Automation (DST)
26. Novel Chiral First Row Transition Metal Complexes for Asymmetric Catalysis via Activation of Inert C-H And C-Heteroatom Bonds (CEFIPRA)
27. Investigate The Role Of Distal-Less Homeobox-1 (Dlx1) In Transdifferentiation Of Prostate Cancer Cells And Neoplastic Progression (SERB)
28. Investigating the role of BMP signaling in pathogenesis of osteoarthritis (DBT)
29. DAPHNE; Delhi Air Pollution Health And Effects (DBT)
30. Indo-UK Joint Project Entitled: Towards An Integrated Approach For Assessing The Impact Of Climatic Stresses On Agriculture And The Exchange Of Green House Gas On The IGP (DST)

31. A hybrid nanoparticle-viral vector system for targeted gene transfer in Acute Myeloid leukemia (DST)
32. Bioactive molecule (TGF β 1 and Wnt/ β -catenin Inhibitor) presenting injectable double network hydrogels for cartilage regeneration (DBT)
33. Regional Hub And Technical Centre(Technology Submission of Pradhan MantriAwasYojna, Ministry of Housing and Poverty Alleviation) (MHPA)
34. Indo-UK Center for education and research in clean energy (DST)
35. Characteritron and Fluidic Thrust Vector Control of GHATAK elliptic nozzle model fitted to miniature gas turbine engine (ADA)
36. Bifunctional Catalysts for Cooperative C-H Bond Cleavage via IntramolecularDeprotonation toward Direct Functionalizations of Alkaness (CEFIPRA)
37. Loop Heat Pipes for Avionics and Terrestrial Applications (IFCPAR)
38. Development of National Blockchain and demonstrate for two strategic applications (NSCS)
39. Enhanced Coal-Bed-Methane and Shale-Gas recovery from underground reservoirs aided by permeability enhancement and CO₂ sequestration-an experimental approach (ONGC)
40. Indigenous 5g Test Bed Design (DOT)
41. Developing Bone Active Molecule Functionalized Biomaterials For Prevention/ Treatment Of Osteoporotic Fractures (DBT)
42. Design &Retrofitment for developing Methanol fuelled large bore engine (EMD 710: 4500hp) for Locomotive marine & Power generation Applications (DST)
43. Design & Development of Aquatic Autonomous Observatory (NiracaraSvayamsasitaVedhshala-NSVS) for In-situ Monitoring, Real Time Data Transmission &Web BasedVisualization (IUSSTF)

44. Streaming Analytics Over Temporal Variables From Air Quality Monitoring (SATVAM) (IUSSTF)
45. Bio NEST - (BIRAC)
46. UI-ASSIST: US India collABorative for smart diStribution System wLthSTorage (IUSSTF)
47. ICME National Hub (TCS)
48. Development of nano-bio-platforms for early diagnostics of chronic diseases (DST)
49. Dynamics of subduction interface and its implication for earthquake generating frictional sliding to volcano feeding partial melting in convergent plate tectonic boundaries (DST)
50. UK India Clean Energy Research Institute (DST)
51. Design and Development of Adoptive Intelligent PHMR for Fuel Transportation Systems(GAIL)
52. Focus Incubation Centre (Technical Textile) (MOT)
53. Re-synchronizable Grid Interactive Inverters for Indian Rooftop Solar PV Systems (DST)
54. Development of a highly efficient and immunologically inert adeno-associated virus based vector system for retinal gene therapy (WT)

Labs/ Facilities developed

1. Established a protein crystallization unit as part of the FIST scheme (BSBE).
2. Dark-Field Scattering Microspectroscopy (SERB) (CHM)
3. Energy Analytics Lab (EAL): Five-year CSR supported funding for setting up of EAL. Agency: Indian Energy Exchange Ltd. PI: Dr. Anoop Singh (IME).
4. Centre for Energy Regulation (CER) Agency: Government of United Kingdom through Department for International Development (DFID). PI: Dr. Anoop Singh (IME).

Software developed

1. TreadWill: automated delivery of cognitive behavioral therapy for depression (BSBE).

Technologies developed

1. Fully autonomous rotary-winged unmanned aerial vehicle (RUAV) of 10 kg class has been developed at IIT Kanpur, and the onboard autopilot software developed for autonomous control and navigation to this class of RUAVs has been transferred to HAL RWR&DC Bangalore (AE).
2. General purpose multi-platform / vehicle autopilot NAAVIK (Navigation for Autonomous Aerial Vehicles by IIT Kanpur) for autonomous control and navigation of fixed and rotary wing UAVs (AE).
3. A new high-efficiency helicopter design has been developed which employs a novel method for anti-torque balancing of the helicopter by employing dissimilar coaxial rotors (AE).
4. Innovative internal combustion engine powered high endurance variable pitch quadrotor Unmanned Air Vehicle has been developed and demonstrated (AE).
5. Variable pitch quadrotortailsitter UAV for payload delivery: a proof of concept prototype has been developed and flight tested, a proposal has been submitted to HAL RWR&DC Bangalore (AE).
6. A novel low-cost high-efficiency Vertical Axis Wind Turbine (VAWT) with dynamic blade pitching (resulting in low startup speed and high power coefficient) suitable for low wind areas have been developed and demonstrated (AE).
7. Developed physics based helicopter comprehensive analysis software called CARMA (AE).
8. Physics-based software for flight dynamic analysis of helicopters has been developed with blade model having full flap-lag-

torsion degrees of freedom, unsteady aerodynamics and dynamic inflow. This software has been transferred to Aeronautical Development Establishment (ADE) for its application in Naval Rotary Unmanned Aerial Vehicle Project (NRUAV) (AE).

9. Developed and demonstrated the flight of world's first Remote Controlled Boomerang UAV called "Sudarshan"; a patent has been filed on this design (AE).
10. Autopilot Development for Fixed-wing and Rotary-Wing Unmanned Vehicles (AE).
11. Designed a prototype development of hand-launched (10kg class) fixed-wing UAV for Tata Advisory Systems Limited (TASL) (AE).
12. Solar UAV fixed wing; the design has been taken over by VTOL Aviation (AE).
13. Design and developed as flight tested a scale model of ADA, Stealth aircraft (AE).
14. Design and developed code to analyse stability aspects of super cavitating projectile (underwater) NSTL Vishakhapatnam (AE).
15. Sulfated polysaccharide mediated growth factor presentation in scaffolds for cartilage tissue engineering (BSBE).
16. A non-invasive nanoparticle-based drug delivery system for the treatment of posterior eye diseases (BSBE).
17. The SPICE model (Titled: ASM-HEMT) developed jointly by Dr. Yogesh Chauhan (EE) has been selected the world's first industry standard model for Gallium Nitride High Electron Mobility Transistor (GaN HEMT) by Silicon Integration Initiative's Compact Model Coalition (CMC).
18. Developed Solar PV driven refrigerated cart for vendors by Akhil Singh Charak (ME).