

## PERFORMANCE-BASED PLASTIC DESIGN (PBPD) METHOD FOR EARTHQUAKE-RESISTANT STRUCTURES

Subhash C. Goel<sup>1</sup>, Shih-Ho Chao<sup>2</sup>, Sutat Leelataviwat<sup>3</sup>, Soon-Sik Lee<sup>4</sup>

<sup>1</sup>Professor Emeritus of Civil Engineering, University of Michigan, Ann Arbor, MI, USA

<sup>2</sup>Assistant Professor of Civil Engineering, University of Texas, Arlington, TX, USA

<sup>3</sup>Assistant Professor, Dept. of Civil Engineering, King Mongkut's University of Technology, Thonburi, Bangkok, Thailand.

<sup>4</sup>Project Engineer, Parsons, Seattle, WA.

Email: subhash@umich.edu, shchao@uta.edu, sutat.lee@kmutt.ac.th

### ABSTRACT :

This paper presents a brief overview of Performance-Based Plastic Design (PBPD) method as applied to seismic design. The method uses pre-selected target drift and yield mechanism as key performance limit states. The design base shear for selected hazard level(s) is calculated by equating the work needed to push the structure monotonically up to the target drift to that required by an equivalent SDOF to achieve the same state. Plastic design is performed to detail the frame members and connections in order to achieve the intended yield mechanism and behavior. The method has been successfully applied to a variety of common steel framing systems, and validated by inelastic static and dynamic analyses. In all cases, the frames developed desired strong column sway mechanisms, and the story drifts and ductility demands were well within the target values, thus meeting the desired performance objectives. Comparisons of responses with corresponding baseline frames designed by current practice have consistently shown the superiority of the proposed methodology. The work-energy equation can also be used in seismic evaluation of structures.

### KEYWORDS:

Performance-based design, Plastic design, Seismic design, Work-Energy equation, Design base shear, Seismic evaluation.

### 1. INTRODUCTION

It is well known that structures designed by current codes undergo large inelastic deformations during major earthquakes. However, current seismic design approach is generally based on elastic analysis and accounts for the inelastic behavior in a somewhat indirect manner. In the current U.S. seismic design practice it is common to obtain design base shear (seismic response coefficient) from code-specified spectral acceleration assuming the structures to behave elastically, and reducing it by certain force modification factor,  $R$ , depending upon assumed ductility of the structural system. This strength demand is increased according to the importance of specific structures by using an occupancy importance factor,  $I$ . After selecting the member sizes for required strengths (obtained from elastic analysis), the calculated drift at design forces is multiplied by a deflection amplification factor,  $C_d$ , and kept within specified limits (generally in the order of 2%). Appropriate detailing provisions are followed in order to meet the expected ductility demands. When struck by severe ground motions, however, the structures designed by such procedures have been found to undergo inelastic deformations in a somewhat "uncontrolled" manner. The inelastic activity, which may include severe yielding and buckling of structural members and connections, can be unevenly and widely distributed in the structure. This may result in rather undesirable and unpredictable response, sometimes total collapse, or difficult and costly repair work at best.

While the above design practice has served the profession rather well in the past, societal demands are pushing the practice to achieving higher levels of performance, safety and economy including life cycle costs. For the

practice to move in that direction, design factors such as, determination of appropriate design lateral forces and member strength hierarchy, selection of desirable yield mechanism, and structure strength and drift etc., for specified hazard levels should become part of the design process right from the start.

Practical design methods are needed to achieve the above mentioned goals. One such complete design methodology, which accounts for structural inelastic behavior directly, has been developed by the senior author and his associates at the University of Michigan (Leelataviwat et al., 1999; Lee and Goel, 2001; Dasgupta et al., 2004; Chao and Goel, 2006a; Chao and Goel, 2006b; Chao et al., 2007; Leelataviwat et al., 2007; Chao and Goel, 2008; Goel and Chao, 2008). The design concept uses pre-selected target drift and yield mechanism as key performance limit states. Results of extensive inelastic static and dynamic analyses have proven the validity of the proposed method. The method has been successfully applied to steel MF, BRBF, EBF, STMF, and CBF. In all cases, the frames developed the desired strong column-weak beam yield mechanisms as intended, and the story drifts/ductility demands were well within the selected design values, thus meeting the selected performance objectives. Comparisons of responses with corresponding baseline frames designed by current practice have consistently shown superiority of the proposed methodology, in terms of achieving the desired behavior.

## 2. BACKGROUND

Use of energy equation in a simple form along with limit state design was first proposed by Housner (1956). Housner used the difference between the input energy and elastic strain energy to obtain the plastic energy to be “absorbed” by the structure as a means to design the designated yielding members. In the example of a steel braced tower for water tank the tension only bracing rods were designed to have adequate plastic energy capacity up to the ultimate strain. In a follow-up paper, Housner (1960) extended this concept to determine the design lateral force to prevent collapse due to overturning at extreme drift. Examples included a simple cantilever column supporting a heavy mass, such as a water tower, and a multi-story building structure. Due to simplicity of the approach and limited available knowledge at that time, a number of assumptions were made.

Housner (1960) observed that during strong ground shaking structures may fail in one of several ways: “*One possibility is that the vibrations will cause approximately equal plastic straining in alternate directions and that this will continue until the material breaks because of a fatigue failure. Another possibility is that all of the plastic straining will take place in one direction until the column collapses because of excessive plastic drift. These two possibilities are extreme cases, and the probability of their occurrence is small. The most probable failure is collapse due to greater or lesser amount of energy having been absorbed in plastic straining in the opposite direction. In this case collapse occurs when some fraction of the total energy  $pE$  is just equal to the energy required to produce collapse by plastic drift in one direction. In what follows, the factor  $p$  will be taken equal to unity as a matter of convenience, ...*”

The energy concept used in the development of PBPD method is very similar to the basic approach used by Housner about 50 years ago. In the PBPD method the relationship between the amount of work needed to push the structure monotonically up to the design target drift and the elastic input energy is derived on a rational basis by using inelastic response spectra for EP-SDOF systems. The method is extended to multi-story structures through equivalent modal SDOF oscillators.

## 3. PERFORMANCE-BASED PLASTIC DESIGN (PBPD) METHOD

The PBPD method uses pre-selected target drift and yield mechanism as key performance limit states. These two limit states are directly related to the degree and distribution of structural damage, respectively. The design base shear for a specified hazard level is calculated by equating the work needed to push the structure monotonically up to the target drift to the energy required by an equivalent EP-SDOF to achieve the same state (Figure 1). Also, a new distribution of lateral design forces is used (Chao et al., 2007), which is based on relative distribution of

maximum story shears consistent with inelastic dynamic response results. Plastic design is then performed to detail the frame members and connections in order to achieve the intended yield mechanism and behavior.

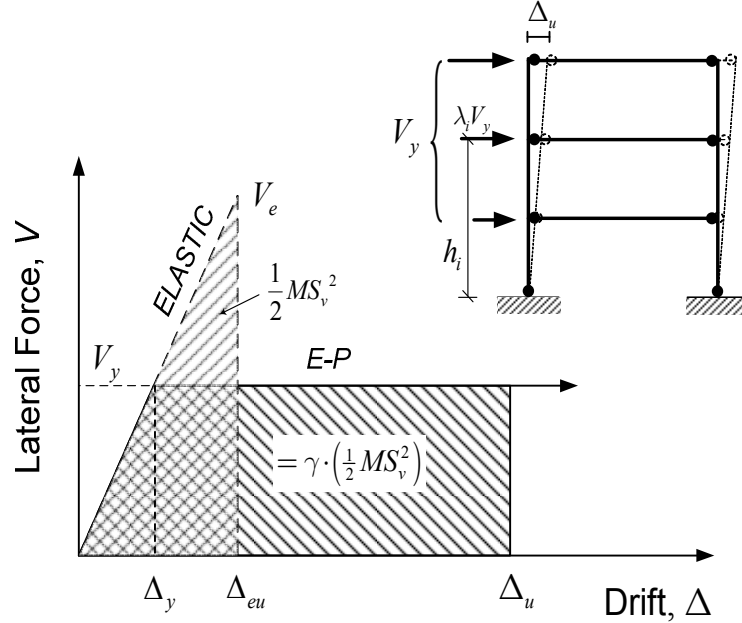

Figure 1 PBPD concept

It should be noted that in this design approach the designer selects the target structural drifts (corresponding to acceptable ductility and damage), and yield mechanism (for desirable response, and ease of post-earthquake damage inspection and reparability), and determines the design forces and frame member sizes for a given earthquake hazard (spectrum). There is no need for factors, such as  $R$ ,  $I$ ,  $C_d$ , etc., as are required in the current design codes and over which plenty of debate already exists. Those factors are known to be based on a number of considerations including engineering judgment.

### 3.1 Design Base Shear

Determination of the design base shear for given hazard level(s) is a key element in the PBPD method. As mentioned earlier, it is calculated by equating the work needed to push the structure monotonically up to the target drift to that required by an equivalent elastic-plastic single degree of freedom (EP-SDOF) system to achieve the same state. Assuming idealized E-P force-deformation behavior of the system, the work-energy equation can be written as:

$$(E_e + E_p) = \gamma \left( \frac{1}{2} MS_v^2 \right) = \frac{1}{2} \gamma M \left( \frac{T}{2\pi} S_a g \right)^2 \quad (3.1)$$

where  $E_e$  and  $E_p$  are, respectively, the elastic and plastic components of the energy (work) needed to push the structure up to the target drift.  $S_v$  is the design pseudo-spectral velocity;  $S_a$  is the pseudo spectral acceleration;  $T$  is the natural period; and  $M$  is the total mass of the system. The energy modification factor,  $\gamma$ , depends on the structural ductility factor ( $\mu_s$ ) and the ductility reduction factor ( $R_\mu$ ), and can be obtained by the

following relationship:

$$\gamma = \frac{2\mu_s - 1}{R_\mu^2} \quad (3.2)$$

The work-energy equation can be re-written in the following form:

$$\frac{1}{2} \left( \frac{W}{g} \right) \cdot \left( \frac{T}{2\pi} \frac{V_y}{W} g \right)^2 + V_y \left( \sum_{i=1}^N \lambda_i h_i \right) \theta_p = \frac{1}{2} \gamma \left( \frac{W}{g} \right) \cdot \left( \frac{T}{2\pi} S_a g \right)^2 \quad (3.3)$$

or,

$$\left( \frac{V_y}{W} \right)^2 + \frac{V_y}{W} \left( h^* \frac{\theta_p 8\pi^2}{T^2 g} \right) = \gamma S_a^2 \quad (3.4)$$

The admissible solution of Eqn. (3.4) gives the required design base shear coefficient,  $V_y/W$ :

$$\frac{V_y}{W} = \frac{-\alpha + \sqrt{\alpha^2 + 4\gamma S_a^2}}{2} \quad (3.5)$$

where  $\alpha$  is a dimensionless parameter given by,

$$\alpha = \left( h^* \frac{\theta_p 8\pi^2}{T^2 g} \right) \quad (3.6)$$

and  $h^* = \sum_{i=1}^N (\lambda_i h_i)$ .

A flowchart of the PBPD procedure is given in Figure 2.

#### 4. EVALUATION

The energy-based PBPD method, thus far, has been presented and discussed in the context of design of new structures for a target maximum drift. Therefore, with other terms being known, the design base shear, is determined by solving the work-energy Eqn. (3.1). The same energy equation can also be used for evaluation purposes, where the structure is defined, including its force-displacement characteristics, and the goal is to “predict” the expected maximum displacement for a given seismic hazard (Leelataviwat et al., 2007). Other response quantities, such as component forces and deformation demands, can be easily calculated from the maximum displacement.

In order to use the energy concept for evaluation purposes, the right hand side of Eqn. (3.1) can be viewed as energy demand for the given hazard,  $E_d$ , and the left hand side as the energy capacity of the given structure,  $E_c$ . Both these quantities vary with displacement. The value of the desired maximum displacement can be obtained by either solving the work-energy equation analytically, or graphically by constructing the two energy curves as a function of displacement and determining their point of intersection.

Figure 3 presents a graphical illustration of the evaluation process. Lateral force-displacement plot for the given structure is shown in Figure 3(a), where  $V$  represents the total force (base shear), and  $u$ , the roof displacement.

This plot can be obtained by a static push-over analysis by applying either an appropriately selected force or displacement pattern. It is common to plot total force versus roof displacement, but it can be done for any other floor or story level from which the force or displacement at other levels can be determined. The energy capacity curve,  $E_c-u_r$ , can be generated as a function of  $u_r$ , by calculating the work done by lateral forces up to the displacement at each level corresponding to  $u_r$ , Figure 3(b). Next, the energy demand,  $E_d$ , can be calculated for varying values of  $u_r$ , and plotted as shown in Figure 3(c). The point of intersection of the two curves, where the energy demand and capacity become equal, gives the desired maximum displacement, as shown in Figure 3(d). Other response quantities can then be easily calculated.

## 5. CONCLUSION

The PBPD method uses pre-selected target drift and yield mechanism as key performance limit states. These two limit states are directly related to the degree and distribution of structural damage, respectively. The design base shear for a specified hazard level is calculated by equating the work needed to push the structure monotonically up to the target drift to the energy required by an equivalent EP-SDOF to achieve the same state. Plastic design is then performed to detail the frame members and connections in order to achieve the intended yield mechanism and behavior. The work-energy equation can also be used for evaluation purposes where the goal is to determine expected displacement demand for a given structure and earthquake hazard.

## REFERENCES

- Chao, S.-H., and Goel, S.C. (2006a). Performance-based design of eccentrically braced frames using target drift and yield mechanism. *AISC Engineering Journal* **3<sup>rd</sup> Quarter**, 173-200.
- Chao, S.-H., and Goel, S.C. (2006b). A seismic design method for steel concentric braced frames (CBF) for enhanced performance. *Proceedings of Fourth International Conference on Earthquake Engineering*, Taipei, Taiwan, October 12-13, Paper No. 227.
- Chao, S.-H., Goel, S. C., and Lee, S.-S. (2007). A seismic design lateral force distribution based on inelastic state of structures," *Earthquake Spectra* **23:3**, 547-569.
- Chao, S.-H., and Goel, S. C. (2008). Performance-based plastic design of seismic resistant special truss moment frames. *AISC Engineering Journal* **2<sup>rd</sup> Quarter**.
- Dasgupta, P., Goel, S.C., and Parra-Montesinos, G. (2004). Performance-based seismic design and behavior of a composite buckling restrained braced frame (BRBF). *Proceedings of Thirteenth World Conference on Earthquake Engineering*, Vancouver, Canada, Paper No. 497.
- Goel, S.C., and Chao, S.-H. (2008). Performance-Based Plastic Design: Earthquake Resistant Steel Structures, International Code Council, U.S. (Under publication)
- Housner, G.W. (1956). Limit design of structures to resist earthquakes. *Proceedings of First World Conference on Earthquake Engineering*, Earthquake Engineering Research Institute, San Francisco, 5,1-11.
- Housner, G.W. (1960). The plastic failure of structures during earthquakes." *Proceedings of Second World Conference on Earthquake Engineering*, Tokyo, Japan, 997-1012.
- Lee, Soon-Sik, and Goel, S.C. (2001). Performance-based design of steel moment frames using target drift and yield mechanism. *Research Report No. UMCEE 01-17*, Dept. of Civil and Environmental Engineering, University of Michigan, Ann Arbor, MI.
- Leelataviwat, S., Goel, S.C., and Stojadinović, B. (1999). Toward performance-based seismic design of

structures.” *Earthquake Spectra*, **15(3)**, 435-461.

Leelataviwat, S., Saewon, W., and Goel, S.C. (2007). An energy based method for seismic evaluation of structures. *Proceedings of Structural Engineers Association of California Convention SEAOC 2007*, Lake Tahoe, California, 21-31.

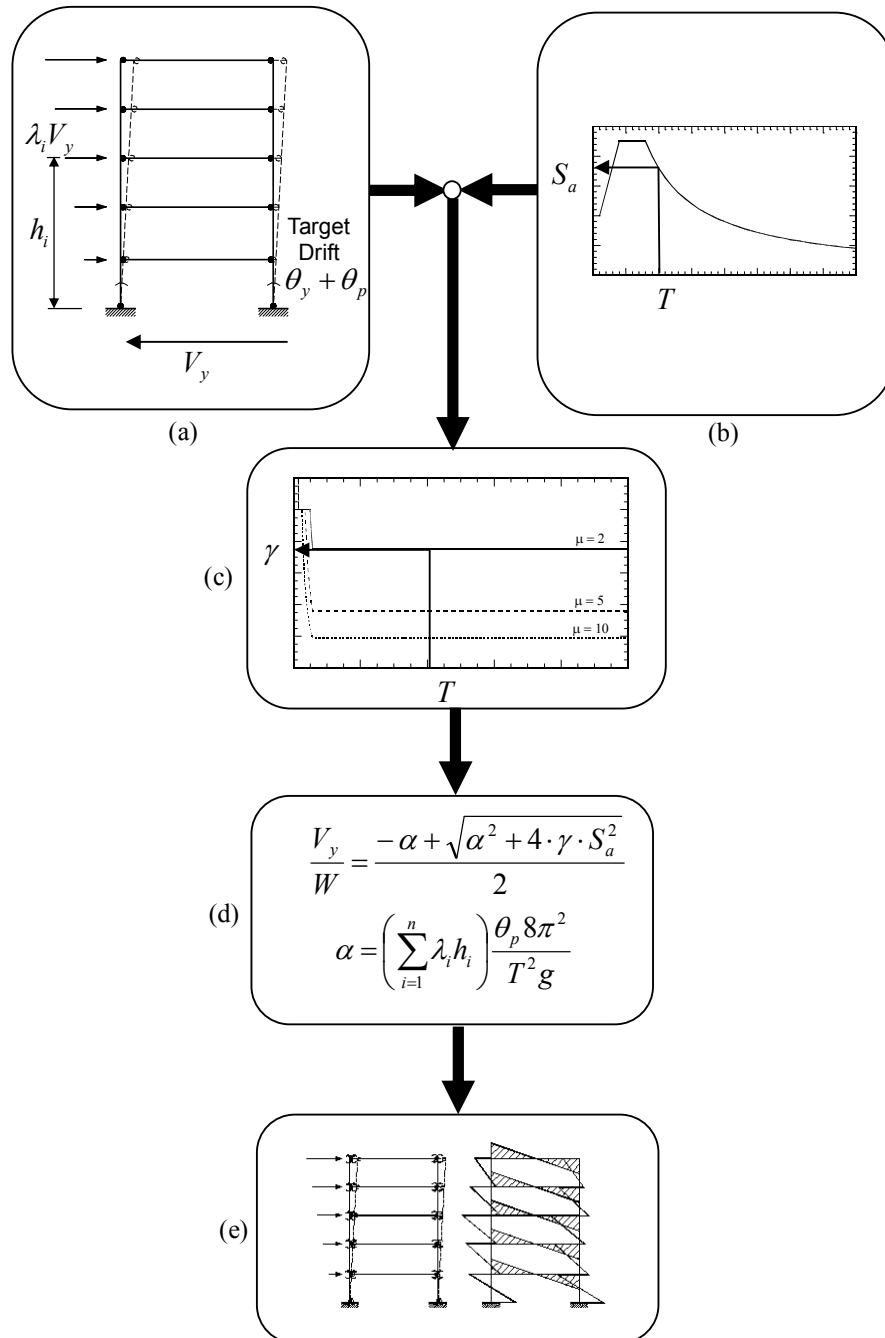

Figure 2 Summary of PBPD steps: (a) Selection of target performance (story drift and yield mechanism); (b) Selection of hazard level; (c) Determination of energy factor; (d) Determination of design base shear based on energy concept; (e) Plastic design of frame members

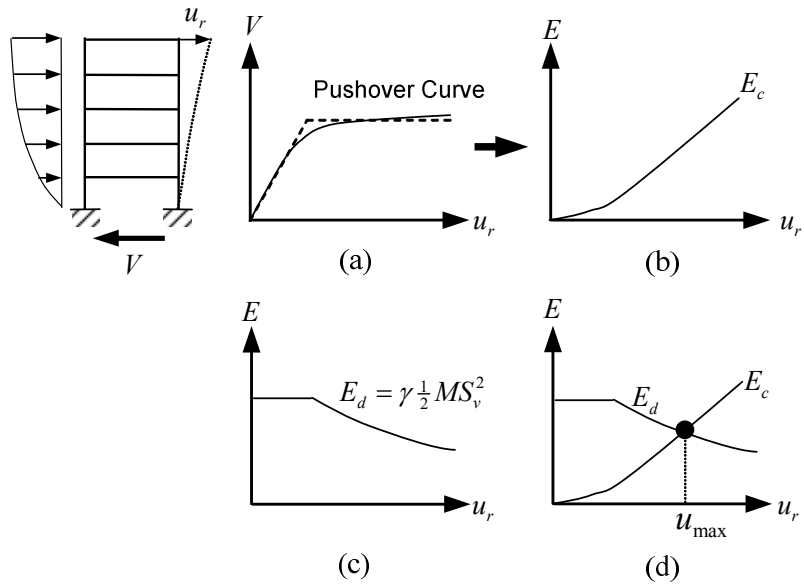

Figure 3 Proposed energy-based evaluation method for MDOF systems: (a) Push-over curve, (b) Energy-displacement capacity diagram, (c) Energy demand diagram, and (d) Determination of displacement demand