

SEISMIC RESPONSE OF BUCKLING-RESTRAINED BRACED FRAMES WITH BEAM SPLICES

G.S. Prinz¹, P.W. Richards² and S. Fremming³

¹ Graduate Research Assistant, Dept. of Civil and Environmental Engineering, Brigham Young Univ., Provo, UT 84602; Email: gprinz@byu.edu

² Assistant Professor, Dept. of Civil and Environmental Engineering, Brigham Young Univ., Provo, UT 84602
Email: prichards@et.byu.edu

³ Undergraduate Research Assistant, Dept. of Civil and Environmental Engineering, Brigham Young Univ., Provo, UT 84602

ABSTRACT :

Buckling-restrained braced frames (BRBFs) are used in steel buildings to resist lateral earthquake loads. The system ductility of typical BRBFs is limited by the performance of the beam-column-gusset connection regions at large drifts. Experiments have indicated that connection ductility may be improved by splicing the beam outside the gusset region. Dynamic analyses were performed to investigate the impact of these beam splices on the seismic response of BRBFs. Two series of analyses were performed. In the first series, BRBF frames were analyzed as two dimensional systems subjected to in-plane loading. Beam splices were modeled using rotational springs. The impact of the strength and stiffness of the splice was investigated. Frames were subjected to a suite of ten ground motions scaled to represent design events. The second series of dynamic analyses involved more advanced models. Three dimensional models were developed where connection regions including the gusset plates were modeled with shell elements. These models were subjected to ground accelerations oriented at different angles to the frame. Models were considered with and without beam splices outside the gusset region. The use of beam splices proved effective in reducing stress build-up in the gusset-to-beam and gusset-to-column connecting regions. Maximum gusset stresses in the first story beams and columns had a 50 percent reduction in magnitude. Adding beam splices had negligible impact on drifts.

KEYWORDS: Finite Element Analysis; Seismic Loads; Steel Frames

1 INTRODUCTION

Design of steel structures for seismic loads generally allows for structural damage during severe seismic events. The typical design objective is to limit material yielding to specific locations and to provide enough ductility in the system to prevent collapse. Such a design is achieved through specially detailed braced frames and moment frames. This paper discusses one type of ductile braced frame system, called buckling-restrained braced frames (BRBFs).

Since their introduction from Japan to the United States in the late 1990's, buckling-restrained braces have undergone extensive testing by U.S. researchers, demonstrating good performance in both tension and compression (Inoue et al 2001; Black et al. 2004; Sabelli et al 2003; Tremblay et al. 2006). This symmetric hysteretic behavior provides improved ductility over traditional braces which are limited by poor post-buckling resistance to compressive loads.

Although buckling-restrained brace testing demonstrates good brace performance, BRBF testing indicates the potential for undesirable failure modes within connection regions at large deformations (Aiken et al., 2002; Roeder et al., 2006). These failure modes include: fracture of the beam-to-gusset and column-to-gusset welds, beam local buckling, and column local buckling (see Figure 1, next page).

A prototype BRBF connection tested by Coy (2007) prevented damage to the gusset, beam, and column through the use of beam splices. The connection used flange connector plates across the splice (see Figure 2) and was based on a design proposed by Walters et al. (2004) which had both web and flange connector plates. With the connector plates only located at the top flange, the entire lateral load is transferred at the flange level, minimizing any moment couple between the splice connection and concrete slab. Component testing of the beam-splice BRBF connection sustained drifts in excess of 6 percent with inelastic deformation limited to the flange connector plates. The loading was applied in the plane of the BRBF using a static loading protocol.

A full-scale four story frame tested by Fahnestock et al. (2007) also incorporated BRBFs with beam splice connections. The splice connections were located outside the gussets with structural T's joining the beam sections at the web. Testing results from pseudo-dynamic loading showed the connection sustained frame drifts of near 0.05 rad, exceeding typical BRBF frame drift demand which is between 0.02 and 0.025 rad (Fahnestock et al. 2007). The frame was subjected to in-plane loading only.

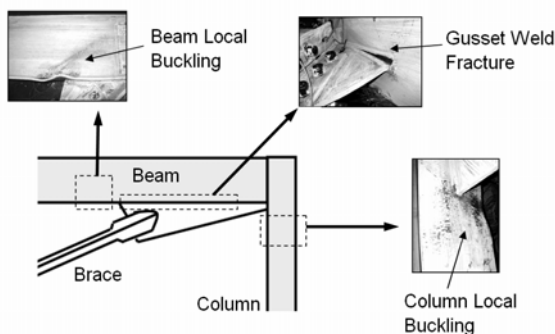

Figure 1 BRBF connection failures
(Photos from Christopolus, 2006)

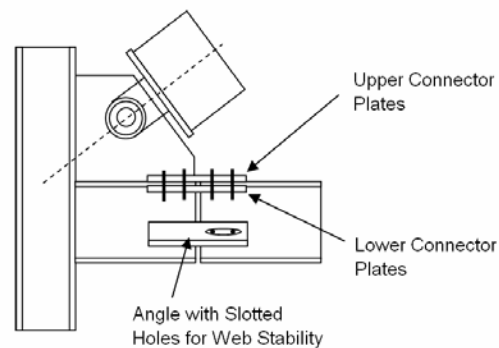

Figure 2 Pinned connection with flange connector plates
(Coy, 2007)

1.1 Objective

This study expanded upon the research performed by Coy (2007) by considering the beam-splice flange connection at the system level under dynamic loads. Traditionally a dynamic study lends itself to shake-table testing with full-scale steel specimens; however, shake-table testing is expensive and requires extensive laboratory resources. For this reason, validated computer models of BRBFs were used as a less expensive and time saving method for obtaining data from dynamic loading.

In this study, two series of dynamic analyses were performed. In the first series, BRBF frames were analyzed as two dimensional systems subjected to in-plane loading. In the second series, more advanced models considering connection geometry were analyzed as three dimensional systems subjected to both in and out-of-plane loading. Ground accelerations recorded from past seismic events were used to load the frames.

2 COMPUTER MODELING

2.1 Prototype Building

A three story doubly symmetric building was designed with BRBFs in one direction and special moment frames in the other (see Figure 3). Exploiting symmetry, only one quarter of the building's seismic system was considered. The bay dimensions (see Figure 3) and floor masses were taken from a SAC study (Gupta and Krawinkler, 1999). The design spectra was from a Los Angeles, California site (see Figure 4, next page, for design spectra). Proportioning of all structural elements is presented in Prinz (2007). Two designs were developed: one with standard connections and another with beam splices outside the gusset plates (Figure 5).

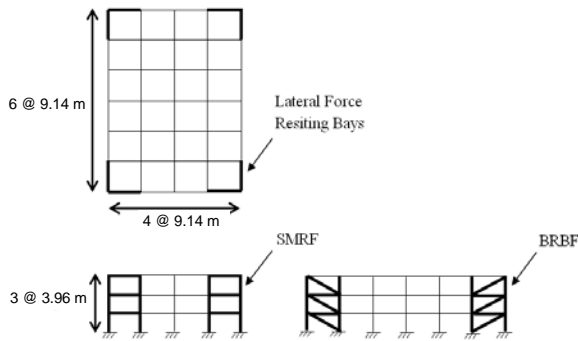

Figure 3 Plan and elevation view of 3-story building

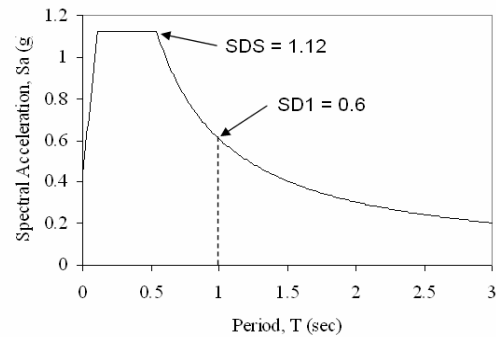

Figure 4 Design response spectra

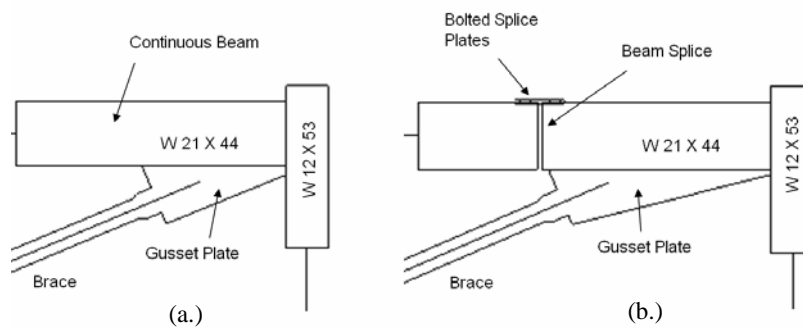

Figure 5 (a.) Typical BRBF connection; (b.) hinged BRBF connection

2.2 Programs and Elements

2.2.1 In-Plane Models

Models were developed for in-plane dynamic loading using the program Ruaumoko (Carr 2004). Individual frames were modeled as two dimensional systems (see Figure 6). Standard beam elements with bi-linear flexural-axial hinges at each end were used to represent beams and columns. Braces were modeled using a truss element with multi-linear kinematic-type hardening. The experimental data used to calibrate the brace hardening was from Merritt et al. (2003) and Reaveley et al. (2004). The splices were modeled with rotational springs. The rotational spring parameters (stiffness and yield strength) were varied from model to model to investigate the impact on dynamic response.

Three in-plane models were developed. The only difference in the models was the stiffness and strength of the rotational springs used to simulated the pinned connection. In one model, the spring stiffness and strength corresponded to the calculated values for the splice plates. In another model, zero rotational stiffness was assumed for the rotational springs (theoretical pinned connection). In the final model, large stiffness and strength was assumed for the rotational spring essentially simulating the typical case where no splice is present.

2.2.2 Three-Dimensional Models

To model the prototype building and investigate connection performance, two 3-story BRBFs having different gusset connections were developed and analyzed as 3-dimensional systems using the finite element program ABAQUS (HKS, 2006). The first frame had typical BRBF gusset connections, and the second frame incorporated a beam splices. Figure 5 (above) shows a side-by-side comparison of the typical (unhinged) BRBF connection and the hinged BRBF connection. Shell elements were used to model all connection geometries in ABAQUS.

In modeling the hinged BRBF connection, the connector plates were spaced away from the beam flange using rigid bolts. The spacing corresponded to the plate centerline location. This modeling technique is validated in Prinz (2007). The connecting bolts were modeled using 1-dimensional beam elements with 7/8" diameter bolt area properties. Consideration of bolt slip was outside the scope of this study.

In regions with simple geometry and no expectation of yielding, 1-dimensional beam elements were inserted to replace the shell elements and reduce analysis computation time. At the transition between the shell and beam elements, rigid-body nodal ties of each type of element were referenced to a common node, ensuring moment transfer between the two element types.

2.3 Model Boundary Conditions

2.3.1 General

Because the computer models represent the lateral force resisting system for one quarter of a building, the influence from the remaining structure (concrete slab and gravity bays) needed to be modeled using boundary conditions. To simulate the action of a concrete slab, column displacements within each floor level were constrained to be equal. The bases of the columns were fixed simulating a relatively rigid foundation. Figure 6 and Figure 7 show the imposed constraints.

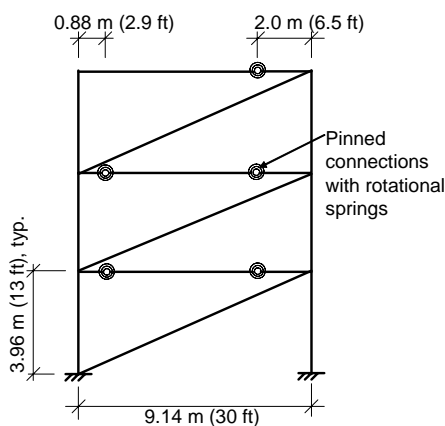

Figure 6 Model for in-plane analysis

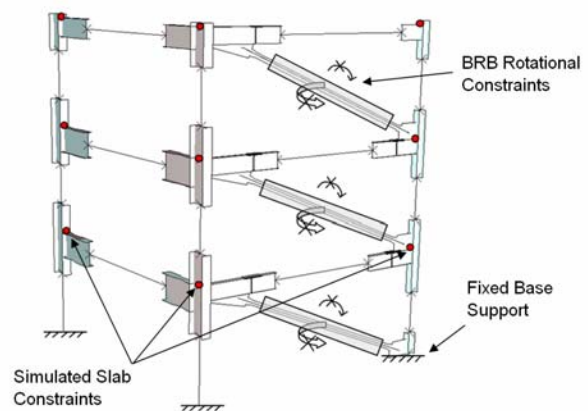

Figure 7 Model for 3-D analysis

2.3.2 3-Dimensional Specific

Because only the brace core was modeled, the influence from confining materials (concrete and steel casing) needed to be specified with boundary conditions. To simulate confinement of the brace core and prevent the brace from buckling out of plane, rotation constraints (both in and out of plane) were implemented along the brace length (see Figure 7). Based on a drift of 4%, the brace core was calculated to strain 3" out of the confining material; therefore, the rotation constraints were not implemented within 3" of the brace-gusset connection. Column rotational constraints were also implemented to simulate the geometric symmetry.

All material properties were obtained from cyclic testing and 5 percent stiffness proportional damping was specified in the first mode. A multi-linear stress-strain curve, determined from brace testing, was used for the brace material property (Coy, 2007). A nonlinear material curve obtained from cyclic coupon testing of A572 Gr. 50 steel (Kaufmann et al., 2001) (similar to A992 steel), was used for the beams and columns. A bilinear stress-strain curve of A36 steel modeled the material for the splice plates and brace gussets. For the purpose of this study, the brace material yield stress was considered to be 46 ksi.

2.4 Frame Loading

2.4.1 In-plane Models

Each of the in-plane models were dynamically loaded with ten earthquake acceleration time histories, scaled to match the design spectra at the fundamental period of the frames. See Table 1 and Figure 8 for earthquake information

Table 1 Earthquakes used for in-plane loading

Record	PGA ^a (g)	Scale Factor
1989 Loma Prieta		
Gilroy array No.3	0.37	2.57
Gilroy array No. 4	0.21	2.73
Hollister City Hall	0.25	1.44
Hollister differential array	0.28	1.52
Sunnyvale-Colton Ave.	0.21	3.49
1994 Northridge		
Canoga Park-Topanga Can.	0.42	1.53
Northridge-17645 Saticoy St.	0.37	2.55
1987 Superstition Hills		
El Centro Imp. Co. Cent.	0.36	2.13
Plaster City	0.19	6.47
Westmoreland Fire Station	0.17	4.20

^a Peak ground acceleration

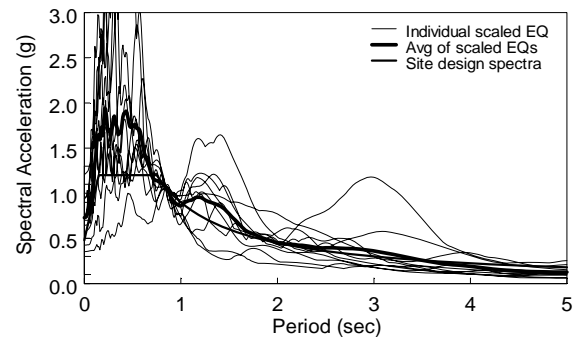

Figure 8 Spectra of earthquakes used for in-plane loading

2.4.2 3-Dimensional Models

The two 3-dimensional test models were loaded using a scaled version of the Loma Prieta, Agnews State Hospital, acceleration record. The scale factor used to match the design response spectra at the fundamental period of the prototype frame ($T_1=0.734$ sec) was 3.49. Three different directions of the ground acceleration, relative to the model, were considered. The relative directions include: 0° (plane of the BRBFs), 45°, and 90° (plane of the special moment frames).

3 RESULTS

3.1 Story Drifts

Splicing the beam and creating a hinge connection has some effect on story drift. Story drifts from the in-plane model are indicated in Figure 9. The drifts shown are the average value of the maximum story drifts under each earthquake. Drifts are actually lower in the bottom story when the beam is spliced, but a little higher in the upper two stories. The response of the system with realistic stiffness and strength is essentially the same as the response of the system with theoretical pinned connections. This may justify a simpler modeling approach for future studies.

Similar results were observed in the 3-dimensional analyses, although the difference between the hinged and unhinged cases is lower. In-plane story drifts for the hinged and unhinged 3-dimensional test frames are presented in Figure 10. Story drifts for the hinged case are within 3 percent of those for the unhinged case when loaded in-plane of the BRBF. Story drifts for the hinged and unhinged connections differed by less than 5 percent when loaded in the out-of-plane directions. The single earthquake that the 3-dimensional frames were analyzed with appears to be less severe than the average of the suite used for the in-plane models. The angle of loading relative to the frames affects the magnitude of the in-plane story drifts in the manner expected. In-plane story drift values of the BRBFs decreased as the loading direction changed from 0 to 45 degrees. The maximum BRBF drifts for the 45 degree out-of-plane loading were nearly 30 percent less than those recorded from the BRBF in-plane loading. This is expected, since only 70.7 percent ($\cos 45^\circ$) of the load is acting in the plane of the BRBF.

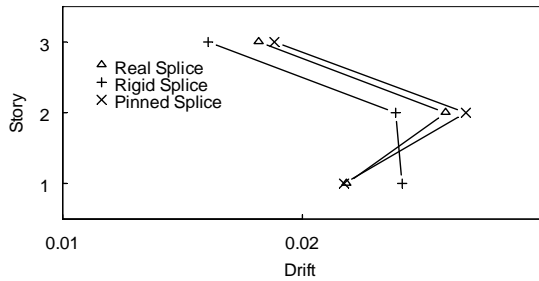

Figure 9 Average maximum story drift for in-plane models

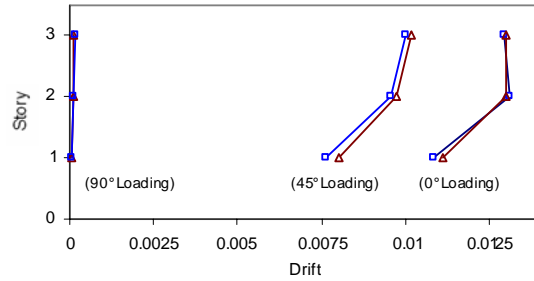

Figure 10 Maximum story drift for 3-D model under 0, 45, and 90 degree excitations

3.2 Gusset Plate Connection Stress

To compare the performance of the different frame connections, stresses were taken at the analysis time corresponding to maximum BRBF drift. This comparison of gusset stresses is valid due to the similar maximum drift values between the models with hinged and unhinged connections (see Figure 10). The distributions of stress in the first floor beam-to-gusset and column-to-gusset connections are presented in Figure 11 through Figure 13. The stress values indicate the hinged connection evenly distributes the stresses along the gusset-to-beam connection, while the unhinged specimen stress values increase away from the column. The stress increase in the unhinged connection is somewhat linear. The maximum gusset stress in the unhinged connection is 63.56 ksi which is over 2 times larger than the highest stress in the hinged connection (29.69 ksi).

The stress values recorded from the 45 degree loading exhibit similar patterns found with the in-plane loading (see Figure 11 and Figure 12). With the exception of the 1st floor upper hinge connection (shown in Figure 11), the 45 degree stress values are less in magnitude (20 to 50 percent less) than the in-plane stress values. This increase in connection stresses for the 45 degree loading may be explained by beam torsion experienced during the out-of-plane loading. It is important to note that no additional yielding resulted from the beam torsion, and the presence of a concrete slab would most likely prevent significant twisting of the beams.

Splice plate deformation in the hinged specimen allowed the beam (at the gusset connection) and column to remain perpendicular as the frame deformed laterally. This resulted in reduced moments at the beam-column interface. In the typical frame connection, there was no hinge mechanism to prevent moments from developing, resulting in higher stresses at the ends of the gusset connections.

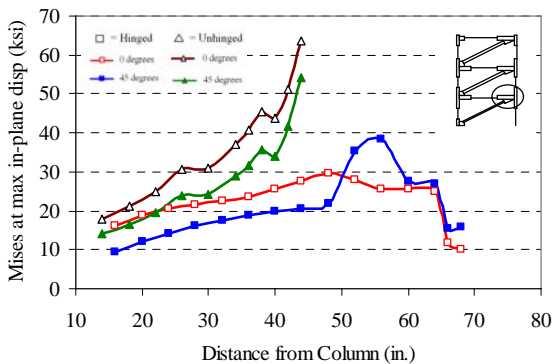

Figure 11 First floor beam-to-gusset connection stresses (0 and 45 degrees) in upper gusset connection

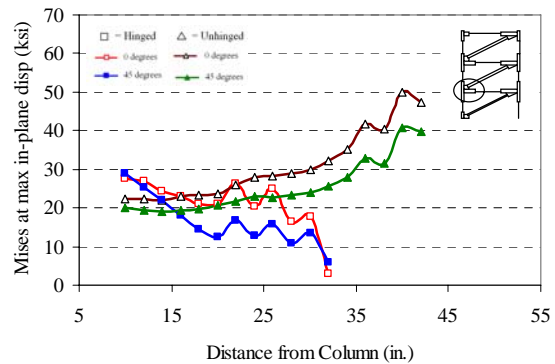

Figure 12 First floor beam-to-gusset connection stresses (0 and 45 degrees) in lower gusset connection

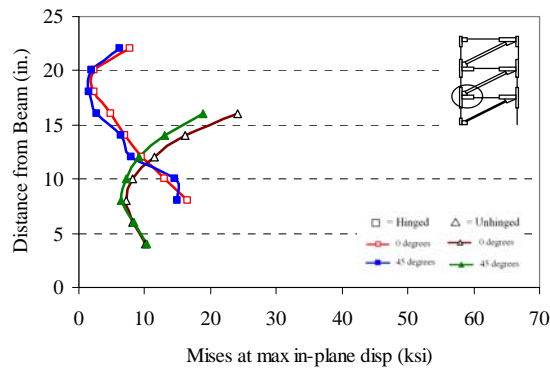

Figure 13 First floor lower column-to-gusset connection stresses (0 and 45 degrees)

4 CONCLUSIONS

In this study, finite element analysis with dynamic loading was used to assess BRBF out-of-plane behavior and the effects of beam splices in improving BRBF connection rotation capacity. Earthquake ground accelerations provided dynamic building loads comparable to design-level seismic events.

Conclusions from the BRBF study with beam splices are as follows:

- 1) Including a beam splice in the BRBF can significantly reduce moments and stress concentrations in the beam-to-gusset and column-to-gusset connecting regions.
- 2) Beam splicing has little effect on BRBF system stiffness or strength.
- 3) Out-of-plane loads decrease stresses in the gusset-to-column and gusset-to-beam connections.

REFERENCES

- Aiken, I.D., Mahin, S.A., and Uriz, P.R. (2002). "Large-scale testing of buckling restrained braced frames." *Proceedings of the Japan Passive Control Symposium*, Tokyo Institute of Technology, Japan, December 2002.
- Black, C. J., Makris, N., and Aiken, I. D. (2004). "Component testing, seismic evaluation and characterization of buckling-restrained braces." *J. of Struct. Eng.*, **130**:6, 880-894.
- Carr, A., (2004). *Ruaumoko Manual*. University of Canterbury, New Zealand.
- Chi, W.-M., Kanvinde, A. M., and Deierlein, G. G. (2006). "Prediction of ductile fracture in steel connections using SMCS criterion." *J. of Struct. Eng.*, **132**:2, 171-181.
- Coy, B. B. (2007). "Buckling-restrained brace connection design and testing." Master's thesis, Brigham Young University, Provo, UT.
- Christopoulos, A. (2006). "Improved Seismic Performance of Buckling Restrained Braced Braces," *Masters Thesis*, University of Washington, Seattle, WA.
- Fahnestock, L.A., Ricles, J.M, and Sause, R. (2007). "Experimental evaluation of a large-scale buckling-restrained braced frame", *J. of Struct. Eng.*, **133**:9, 1205-1214.

- Gupta, A., Krawinkler, H. (1999). "Prediction of seismic demands for SMRFs with ductile connections and elements." *Report No. SAC/BD-99/06*, SAC Joint Venture, Sacramento, CA.
- Hancock, J. W., and Mackenzie, A. C. (1976). "On the mechanics of ductile failure in high-strength steel subjected to multi-axial stress-states." *J. Mech. Phys. Solids.*, **24:3**, 147-160.
- HKS (2006). *ABAQUS Standard Users Manu, Version 6.41*, Hibbitt, Karlsson, and Sorensen, Inc., Providence, RI.
- Inoue, K., Sawaizumi, S., and Higashibata, Y. (2001). "Stiffening requirements for unbonded braces encased in concrete panels." *J. of Struct. Eng.*, **127:6**, 712-720.
- Kaufmann, E. J., Metrovich, B. R., and Pense, A. W. (2001). "Characterization of cyclic inelastic strain behavior on properties of A572 Gr. 50 and A913 Gr. 50 rolled sections." *ATLSS Rep. No. 01-13*, National Center for Engineering Research on Advanced Technology for Large Structural Systems, Lehigh Univ., Bethlehem, Pa.
- Merritt, S., Uang, C.-M., and Benzoni, G. (2003). "Subassemblage testing of Corebrace buckling-restrained braces." *TR-2003/01*, Dept. of Struct. Eng., Univ. of California at San Diego, La Jolla, Calif.
- Prinz, G.S. (2007). "Effect of beam splicing on seismic response of buckling restrained braced frames." Master's thesis, Brigham Young University, Provo, UT.
- Ricles, J. M., Fahnestock, L. A., and Sause, R. (2007). "Studies of earthquake-resistant buckling restrained braced frame systems." *Proceedings of the North American Steel Construction Conference*, AISC, New Orleans, LA, April 2007.
- Reaveley, L., Okahashi, T., and Fatt, C. (2004). *Corebrace Series E Buckling Restrained Brace Test Results*, Dept. of Civil and Env. Eng., Univ. of Utah, Salt Lake City, Utah.
- Roeder, C. W., Lehman, D. E., Christopoulos, A. (2006). "Seismic performance of special concentrically braced frames with buckling restrained braces." *Proceedings of the 8th U.S. National Conference on Earthquake Engineering*, San Francisco, CA, Paper No. 1503.
- Sabelli, R., Mahin, S., and Chang, C. (2003). "Seismic demands on steel braced frame buildings with buckling-restrained braces", Elsevier Science Ltd., *Engineering Structures*, **25:2003**, 655-666
- Tremblay, R., Bolduc, P., Neville, R., and DeVall, R. (2006). "Seismic testing and performance of buckling-restrained bracing systems" *Canadian J. of Struct. Eng.*, **33**, 183-198.
- Walters, M. T., Maxwell, B. H., and Berkowitz, R. A. (2004). "Design for improved performance of buckling-restrained braced frames." *SEAOC 2004 Convention proceedings*, 506-513.