

Assessment of the seismic behavior of eccentrically braced frame with double vertical link (DV-EBF)

Mohsenali Shayanfar¹, Alireza Rezaeian², Sina Taherkhani³

¹Professor, Dept. of Civil Engineering, Iran University of Science and Technology

²PhD Candidates, Dept. of Civil Engineering, Iran University of Science and Technology

³Master Student, International University of Imam Khomeini

Email: shayanfar@iust.ac.ir, farid_rezaeian@yahoo.com, sinacivilika@yahoo.com

ABSTRACT

In this paper, first, the design of eccentrically braced frame with double vertical link is explained. It is worth noting that the base of the design principals for such frames is the corresponding requirements governed on the design of eccentric frames with single horizontal and vertical links. Then, the stability of one-floor frames with double links is investigated. Furthermore, hysteresis behavior of selected frame samples will be studied. The result of this research reveals proper behavior of the proposed details for the purpose of earthquake resistant design of new buildings and the seismic rehabilitation of the existing structures.

KEYWORDS: Eccentrically Braced Frame, Double Vertical Link, Hysteresis Behavior, Seismic Rehabilitation

1. INTRODUCTION

Because of proper seismic characteristics of eccentrically braced frames (EBFs), the use of this lateral resisting structural system is quite popular in the region with high level of seismicity (Roeder, C.W, Popov, E.P.). In this type of frames a distance is created between the two ends of the bracing members, bracing member and column or bracing member and beam, as illustrated in Figure 1. The created distance is called link (e) as shown in Figure 1. The main function of the link is to provide a weak section in frame in order to provide plastic deformation capacity and dissipate the energy released due to earthquake.

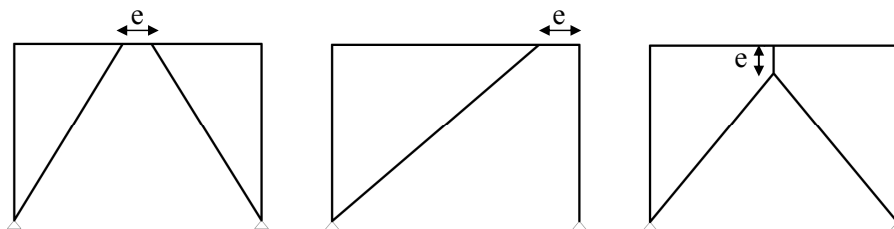

Figure 1 Link in eccentrically braced frame

One of the advantages of vertical links over their horizontal counterparts is the exclusion of plastic deformation from the main structure result on no damage in the roof of the structures under sever earthquakes; easy and simple rehabilitation; and the replacement of link after earthquake (Boukamp, J.G., Vetr, M.G.).

Using the vertical links for seismic rehabilitation of the existing buildings is possible with minor changes in the main structure; however, in large or tall buildings and also in strengthening of the existing structures, due to the limitation of dimensions of the existing components of the structures, the application of the single vertical link has lots of obstacles. For instance, the dimensions of the existing beams limit the size of the link, and consequently more links needed for satisfying the target rehabilitation. This may lead to application of big profiles or built up sections.

The transferred shear from the vertical links, especially in concrete structures, can limit the application of single vertical links. In such case, using double vertical links is recommended, refer to Figure 2, in these details, as the result of two links, the amount of shear on the beam will decrease considerably. Moreover, the recommended details can cause decreasing in the number of bay brace whose result will be the decrease bracing members and their connections. Due to the fact that each link can have a smaller section, welds and bolts will bear less force on the floor beam.

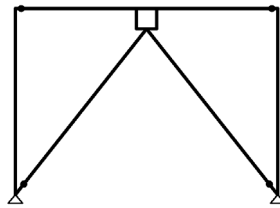

Figure 2 Schematic diagram of double vertical link

The remarkable point in this system is the stability of double links ends in the linking point of the bracing members, because in this place, the links can provide the bracing members with a small out of plane stiffness.

2. DESIGN OF VERTICAL SHEAR HINGES

Shear hinges have a high level of plasticity and energy dissipation capacities (Boukamp, J.G., Vetr, M.G.). The important point in the design of such hinges is the selection of a right length to let the hinge possess plastic deformation and does not involve inelastic instability (buckling). The result of this action is that the shear hinge in the plastic area with a combination of kinematic and isotropic hardening in bending and shearing can get its maximum capacity.

At the limit state, shear hinge due to strain hardening can bear $1.5V_p$ and $1.2M_p$ in which V_p and M_p are plastic shear and plastic moment of the link, respectively. In order to provide the conditions for the formation of shear hinge before the flexural hinge in the horizontal link (considering the free diagram of the horizontal link) Eqn.2.1 is used (Malley, J.o., K.D., Popov, E.P):

$$e \leq \frac{2 \times 1.2 M_p}{V_p} = 1.6 \frac{M_p}{V_p} \quad (2.1)$$

Using link lengths according to the Eqn.2.1 and applying appropriate stiffeners, link can reach a rotation of about 0.1 radian. For vertical shear links whose moment diagram is illustrated in Figure 3, in order to achieve the shear hinge formation conditions before flexural hinge, due to the unequal moment at the end of link Eqn.2.2 is considered (Boukamp, J.G., Vetr, M.G.):

$$e \leq \frac{0.8(\kappa + 1)M_p}{V_p}, \quad \kappa = \frac{M_2}{M_1}, \quad (M_2 \leq M_1) \quad (2.2)$$

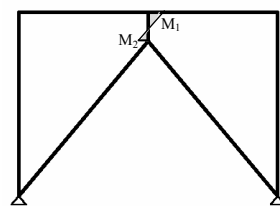

Figure 3 The diagram of the moment in frame with single vertical link

In this paper Eqn.2.2 is considered for shearing behavior. In order to study the behavior of these frames, first a section is chosen for the link, and then the remaining members of the frame are designed for maximum capacity of vertical links. It should be mentioned that the gusset plate of bracing member to the end beam is designed according to the AISC seismic provision 2005 for compression strength of the bracing member.

3. SELECTED SPECIMENS

The main aim of this paper is an investigation for stability and hysteresis behavior of the recommended details for double vertical links. To achieve this, the effects of length change of double link on overall behavior of the frames were studied. For this purpose, three eccentric braced frames with double-vertical links were chosen. The characteristics of the selected specimens are revealed in Table 3.1 and Figure 4.

Table 3.1 Characteristics of the selected specimens

Specimen	Link	e_1 (cm)	e_2 (cm)	t (cm)	h (cm)	L (cm)	N^*	V_p (ton)
1	IPE200	20	35	37	320	450	1	29.56
2	a	35	35	37	320	450	1	29.56
	b	35	35	37	320	450	2	29.56
3	IPE200	50	35	37	320	450	3	29.56

* N is the number of stiffeners

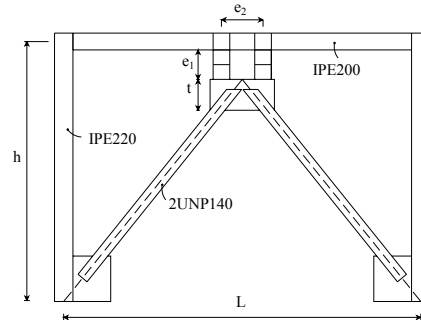

Figure 4 The parametric dimensions of the specimens

The chosen configuration is so that the connection between beam and column and the connection between the column base and the brace to the ground are pin. The link connection to beam and bracing member are also rigid.

4. MODELING AND ANALYSIS

The software ANSYS (Ansys Ver. 5.4.) is used for modeling the specimen. Elements that are used in finite element modeling are: shell 43, solid 65, beam 24. Floor beam and link are made of shell 43. Gusset plate is made of solid 65 in order to prevent stress concentration of transferred loads of bracing member and create an appropriate connection. Bracing member in connection area to the gusset plate is created by shell 43 and the other parts by beam 24 due to low sensitivity. The connection between these two parts has been created by using rigid region capability, due to less importance, column are shown in the structure modeling by beam 24 element, Figure 5.

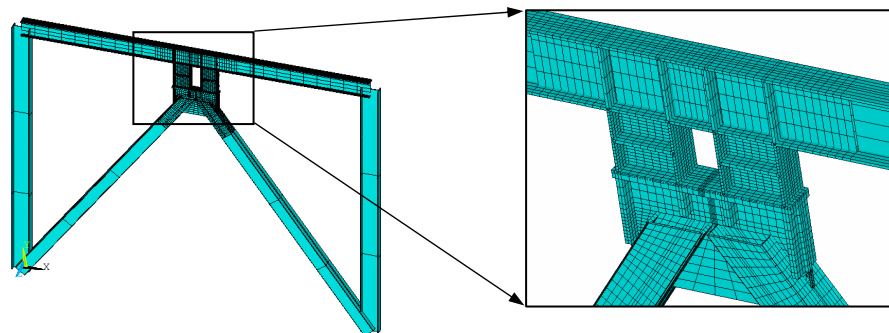

Figure 5 The finite element model of specimen 1

The applied material model for steel is multi linear with yielded stress of 2400 Kg/cm^2 and ultimate stress of 3700 Kg/cm^2 ; elasticity module of steel has decreased 30 percent to account for considering residual stress and imperfection parameters (Qihong.Zhao, Abolhassan Astaneh-Asl).

The employed analyses are: Eigen buckling analysis, nonlinear static analysis under monotonic load and nonlinear static analysis under cyclic load. Eigen buckling analysis is used to estimate the primary critical load of the frame. The first buckling mode shape is attained and the structure is subjected under monotonically increasing load with the activation of large displacement option (to account for geometric nonlinearity). After stability analysis, hysteresis behavior of the specimens is obtained by cyclic static analysis.

5. ANALYSIS RESULTS

5.1 Eigen buckling analysis

For each 3 chosen specimens, Eigen buckling analysis is done and their results (critical load, F_{cr}) are shown in Table 5.1. The first mode of specimen 1 is indicated in Figure 6.

Table 5.1 Critical loads of specimens

Frame	N	$F_{cr}(\text{Ton})$
1	1	207
2	a	191
	b	191.5
3	3	180

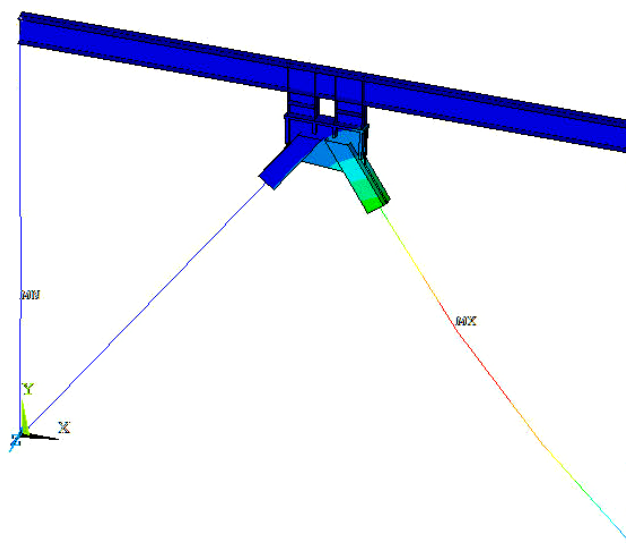

Figure 6 The first mode of specimen 1

As it is clear in Table 5.1 the calculated critical load in all specimens are higher than maximum shear capacity of double links (V_p) even considering strain hardening effects; therefore, it seems that frames will not have any problems regarding stability. These results were confirmed after performing RIKS analysis.

In each three specimens, connection points of bracing member of gusset plate are shown out of plane buckling. Thus the most important issue concerning these specimens is their gusset plate instability.

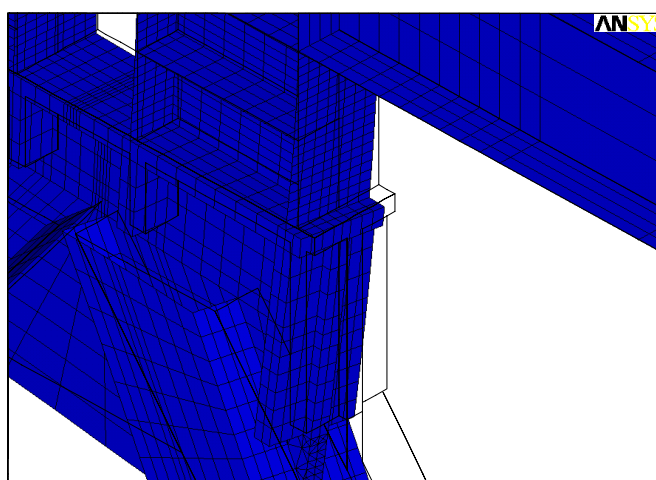

Figure 7 Out of plane buckling of gusset plate

5.2 Stability analyses

In order to investigate probable instability in the frames, RIKS analysis is used. In fact, first mode of buckling was imposed on the structure and large displacement option is activated, then a pushover analysis is performed on the frame in order to find the stability diagram of the frame. In Figure 8 the stability diagrams of all specimens are drawn.

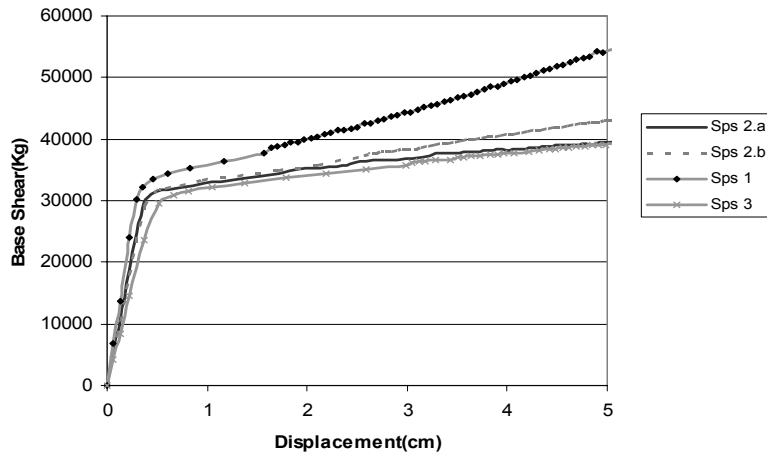

Figure 8 Stability diagrams of specimens

As Figure 8 reveals, none of the specimens within the boundary of yielding and hardening of link have not become unstable; therefore we conclude that out of plane buckling of link ends will not create any problems. Hence, the probability of lateral torsional buckling of end link is almost zero, but shear web buckling of links is occurred at the end of analyses. As shown in Figure 9 von misses criteria with Kg/cm^2 unit and shear web buckling is obvious and the buckling has not been occurred at gusset plate and brace connection zone.

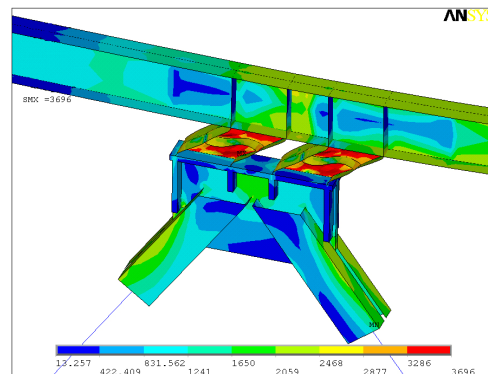

Figure 9 Von misses stress diagram of specimen 1

5.3 Hysteresis diagram

For investigation of hysteresis behavior of the specimens a loading protocol according to Figure 10 was used. This cyclic displacement was enforced to the top of the frames.

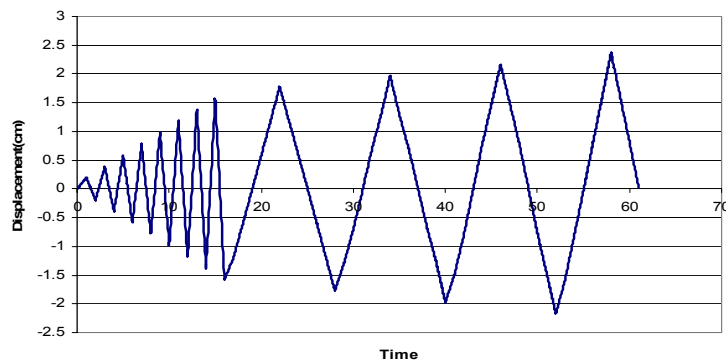

Figure 10 Protocol loading history

According to the results from hysteresis analysis no out of lateral instability at the braces or at gusset plate and brace connection zone was observed. Figure 11 illustrates this observation for specimen 2-a at last step of the hysteresis analysis.

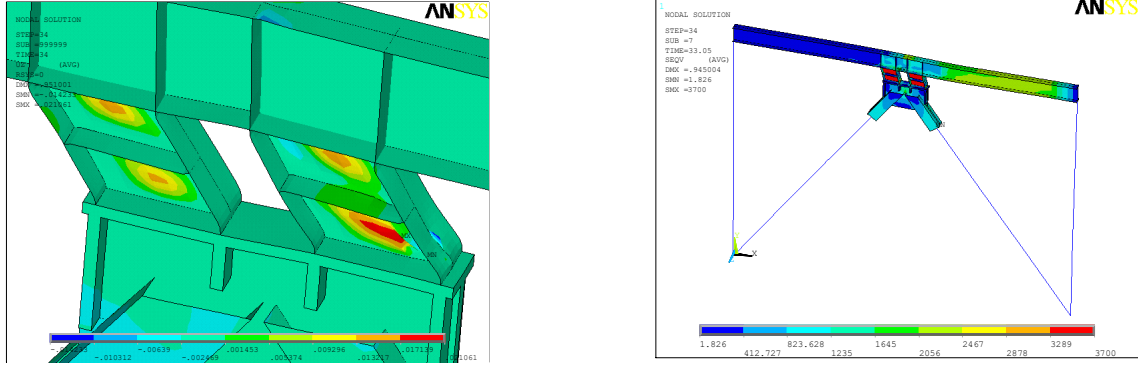

Figure 11 Lateral stability of gusset plate and braces at the end of the hysteresis analysis

In Figure 12 hysteresis diagrams of all the specimens are drawn. In these diagrams the horizontal axis is the roof displacement (cm) and the vertical axis is the base shear force (Kg). As it is depicted in Figure 12, all of the specimens have shown stable behavior.

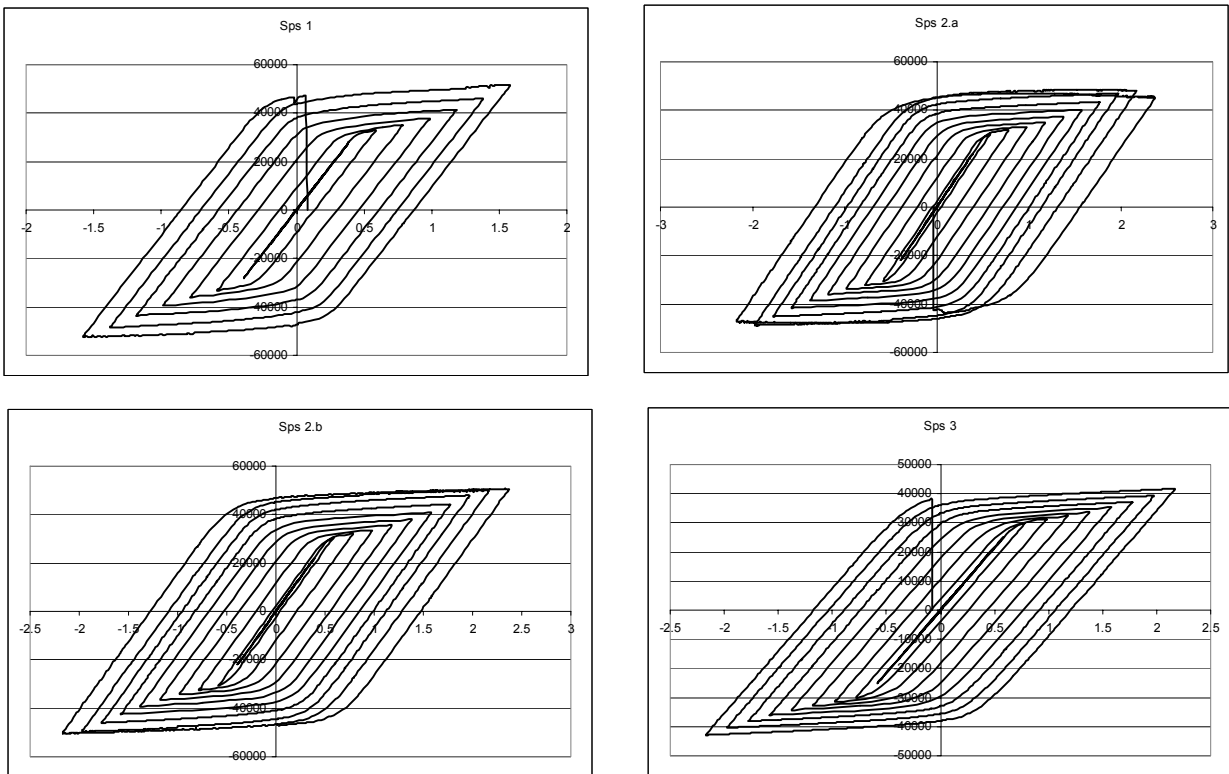

Figure 11 hysteresis diagrams of the specimens

Hysteresis curves for two types of specimen 2 are shown in Figure 12 for comparison purposes. It is obvious that application of two stiffeners led to better results.

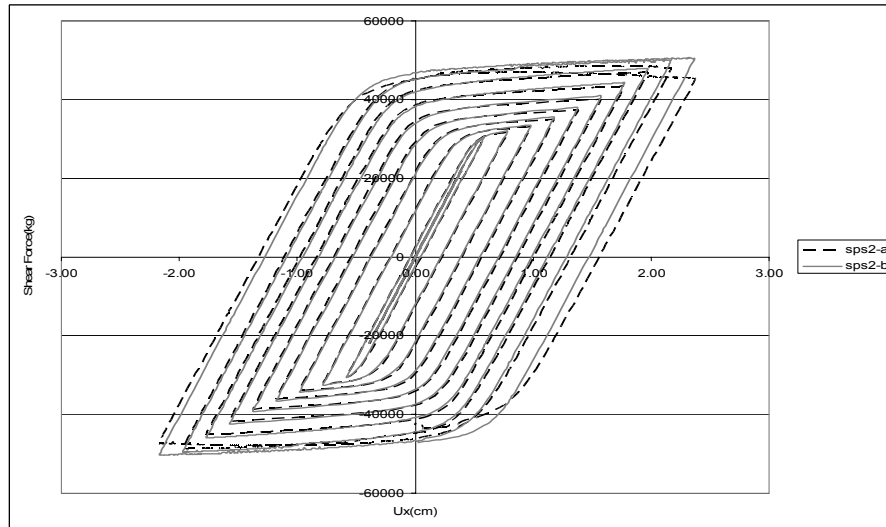

Figure 12 The comparison between hysteresis diagrams of the specimen 2-a and b

As illustrated in Figure 13, the web of all specimens at the last step of hysteresis except specimen 3 went uniformly into the nonlinear area.

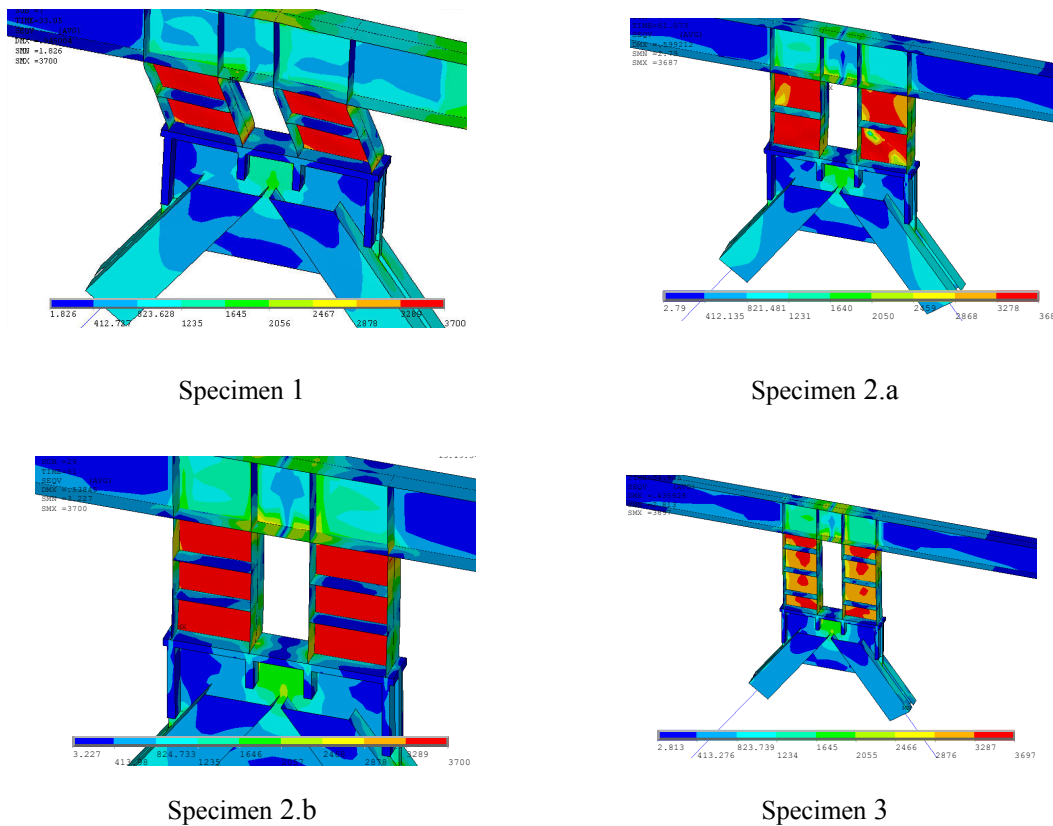

Figure 13 The von misses criteria at the lat step of the hysteresis analysis

6. CONCLUSIONS

As stated before, the aim of this article is the introduction of eccentrically braced frame with double vertical link (DV-LINK) that can be used in the design of new buildings or the rehabilitation of the existing ones. The following results from this study can be concluded:

- 1- Any form of elastic instability (buckling) was not occurred up to the proposed links yielded.
- 2- Hysteresis behavior of double link was stable and bulky which is the sign of their proper seismic behavior.
- 3- Application of two stiffeners instead of one in the second specimen has no effect on the increase in Eigen buckling load; however, it causes an increase in stiffness and strength degradation.
- 4- In all specimens, all non-linear deformations occurred in links which indicates that all the energy dissipation capacity is due to the existence of links and all other parts of the structure remain in the linear range.
- 5- Increase in link length from specimen 1 to 3 caused a decrease in the critical load, rotation, stiffness, and strain hardening which indicates the proper selection of the length of the specimens to reveal shear behavior.

REFERENCES

- Roeder, C.W, Popov, E.P. (1978). Eccentrically braced steel frames for earthquake *J. of Struct. Engrg. ASCE*, Vol.104, 391-411.
- Boukamp, J.G.,Vetr, M.G.(1994). Design of eccentrically braced test frame with vertical shear link. *Proceedings of the 2nd Intl. Con.On earthquake Resistant Construction and Design*, Berlin.
- Malley,J.o.,K.D., Popov,E.P (1983). Design consideration for shear link in eccentrically braced frames. *UCB/EERC-83/24 Report*, Berkeley, California.
- Roeder,C.W., Popov,E.P.(1977). Inelastic of eccentrically braced frame under cyclic loading.*UCB/EERC-77/18*,Berkely,California.
- Ansys Ver. 5.4. (1992). User manual and theory, *Swanson Analysis Systems Inc.*
- ANSI/AISC 341 (2005).Seismic Provisions for steel structural buildings. *American Institute of steel construction*
- Qihong,Zhao, Abolhassan Astaneh-Asl (2007). Seismic Behavior of Composite Shear Wall Systems and Application of Smart Structures Technology. *Steel structures journal*.69-75.