

# A novel drowning detection method for safety of swimmers

Ajil Roy

Department of Instrumentation and Control Engineering  
National Institute of Technology Tiruchirappalli  
Tiruchirappalli, India  
ajil.roy@outlook.com

Dr. K. Srinivasan

Department of Instrumentation and Control Engineering  
National Institute of Technology Tiruchirappalli  
Tiruchirappalli, India  
srinikkn@nitt.edu

**Abstract** - Effective drowning detection methods are essential for the safety of swimmers. In this paper, a novel type of drowning detection method addressing many limitations of prevailing drowning detectors is proposed. The proposed method ensures detection of drowning and reporting at the earlier stages. The proposed drowning detection method is also a generic solution that suits different water bodies from pools to oceans, and an economically viable method useful for both low and middle income countries. The prototype of the drowning detection method is developed and demonstrated and model of the system is simulated in Proteus design suite. The results of the simulation and hardware experimentation are also reported.

**Keywords** - drowning detection, smart sensor surveillance, swimming safety.

## I. INTRODUCTION

Safety in water has been a concern for many centuries for the survival of human lives. The latest technology advancements have enabled to come up with effective drowning detection methods (DDM). A recent report from World Health Organizations (WHO) gives us some insight into the drowning incidents globally. The number of reported drowning deaths globally is 37200. The highest numbers of deaths are in low and middle-income countries. The survey also points that children have the largest death ratio compared to adults. Majority of the drowning deaths are reported from open water bodies likes lakes and sea, and not in pools. In the report WHO has recommended various drowning prevention techniques like constructing fences across the lakes, to prevent accidental fall to teaching school age children swimming as a part of their curriculum in schools.[1]

According to Jeff Ellis and Associates, an International Aquatic Safety and Risk Management Consulting firm, drowning is divided into five stages [2].

Stage 1 - Shocking surprise: This initial stage is characterized by the shock of drowning and difficulty in breathing. The person starts to show a higher level of distress and attempts to reach the surface of the water, but in the vertical direction.

Stage 2 - Involuntary Breath Holding: In this stage attempt to come to surface of water stops. He starts involuntary breath holding. Water has entered the mouth, causes the epiglottis to close. The victims gradually become unconsciousness, as breath is stopped.

Stage 3- Unconsciousness: The victim becomes unconscious, and the body starts to sink to the bottom of the water. Unless breathing is re-established, the victim remains unconscious.

Stage 4- Hypoxic Convulsions: The oxygen level in the brain reduces drastically. The victim's skin turns blue, especially in the lips and fingernail beds.

Stage 5- Clinical Death: Death is the final stage of drowning

Any prediction of drowning during the early stages always reduces risks during the rescue operations.

Drowning is classified into two, active drowning and passive drowning. In the active drowning, the victim express distress that is noticeable to others. In passive drowning, there is no distress exhibited by the victim. The passive drowning happens due to medical reasons like stroke; heart attack etc. or it could be that the person has become unconscious. Passive drowning victims generally have their face down underwater and in some cases will be floating below the surface. All these characteristics make the detection of drowning difficult for even professional lifeguards [3]. With the advancement in technology, various drowning detection methods are available. Some detectors are wearable like Kingii [4]. Another proposed wearable solution is a wearable life jacket which communicates with the life guard and also gets inflated during danger. [5] However many of these wearable systems are designed with a specific use case scenarios. A solution developed for pool might not be effective in the ocean. Another type of detectors is non-wearable. E.g. Video surveillance based systems that focus on taking images of the swimmer and water. The video surveillance comes with few design limitations like unable to work in darkness, prediction depends on the quality of the image, and need of high power computing devices. Various enhancements are provided to the video surveillance methods. [6- 9]

Many DDM designed today have limited scope of usage. DDM developed for pools requires lots of customisation work to make it work for the ocean. E.g. A video surveillance method used in the pool may not be useful to detect drowning in oceans with high waves. The paper address few of the points mentioned in the WHO report, like ease of use to children, economically viable solutions. The children playful nature makes them curious to water and less cautious about the dangers. A wearable DDM should not be impacting his fun while swimming. This will be the most important deciding factor that enables children to use the DDM. To address the above needs, we are proposing a DDM that can be attached to the swimming goggle. During drowning detection, the alarms are transmitted through water and picked up by the receivers/hydrophone placed at different locations in the water body. This is further processed and transmitted to the lifeguard for the rescue operation.

The organisation of paper includes the design of swimming goggles. A system for drowning detection is reported in section II. Section III discusses the block diagram and flowchart representation. The simulation and experimentation is reported in section IV. Section V discusses results. The conclusion and future scope is presented in section VI.

**II. SWIMMING GOGGLES BASED DROWNING DETECTION METHOD**

Drowning detectors detect the drowning by analysing the various readings exhibited during drowning distress, by the victim. This could be like monitoring the waves generated due to panic to monitoring the irregular pressure variations from the gadget, used by the victim. In the method described in this paper, we try a novel method which could predict the drowning. It is obvious that the distress starts as soon as the person reaches the mental barrier point of his breath holding capacity. Maximum breath holding time varies from person to person. An average person can hold breath for 1 to 2 minutes while a 4 year old kid could hold very less duration [10].

If we can develop a system that can trigger alarm in case both mouth and nose are under the water, beyond the breath holding time, we can predict the drowning.

The swimmers, especially children get easily disturbed by placing any sensors very closer to the mouth and nose. They may also try to remove it because of the disturbance. The regular touching on the sensors can also break the unit. Having tried out many alternatives, we have found out swimming goggles are the best place to fit the DDM. This makes the solution acceptable to all age group and does not disturb the swimming pleasure. On the negative side, since water sensor is not placed very close to the nose and mouth, the accuracy of the detection has to depend on redundant water detecting sensors.

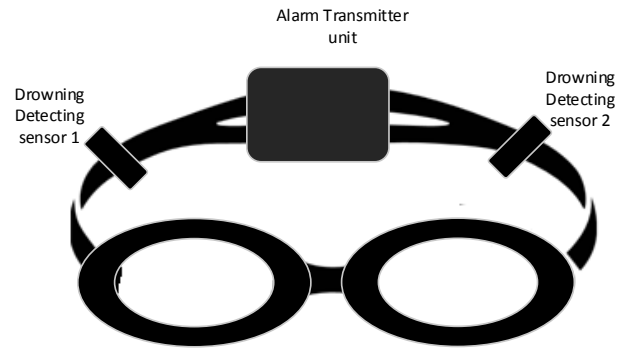

**Fig. 1 Drowning detection enabled swimming goggles.**

Figure 1 shows the parts of the drowning detection system attached to the goggles. Two drowning detection sensors are placed on the side elastic of the goggles. A simple resistive based circuit interfaced with the microcontroller is used. The two Input Output lines of the microcontroller form the resistive circuit. When in air, due the high resistance of air between these wires, the circuit remains open. When immersed in water, the circuit gets completed with the water. The two detectors represent that both sides of the nose and mouth are closed. The Alarm transmission module is used to send the alarms when the drowning is detected. Alarm transmission modules are triggered by drowning detection unit. The Alarms are transmitted using the underwater communication [11].

**III. SYSTEM DESCRIPTION AND FLOWCHART**

Figure 2 represents the system diagram of the drowning detection unit. The entire system consists of drowning detection enabled goggles and an alarm receiver. The alarms from goggles are transmitted under water through existing under water communication technology like acoustic waves, infrared etc. The selection of communication technology is crucial from the range perspective [12]. The bottom portion of the alarm receiver is immersed underwater and top portion faces outside water. The bottom portion receivers picks the alarms transmitted from the victims goggles. These alarms are further processed and transmitted to life guard or concerned authority wired or wireless, depending on the need.

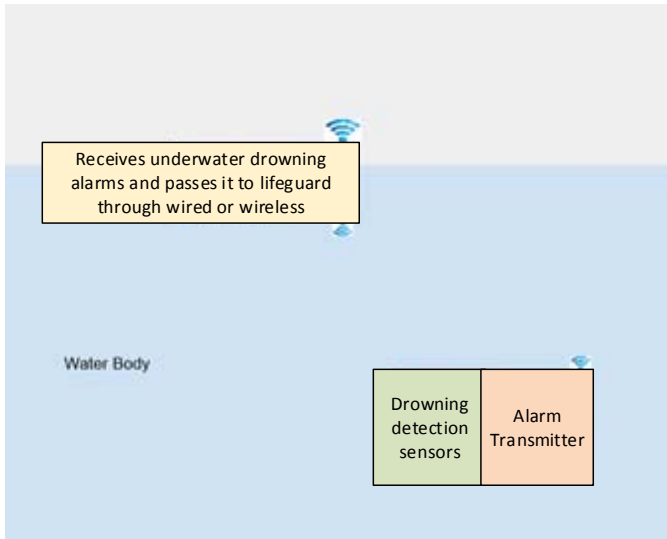

Fig. 2 System block diagram

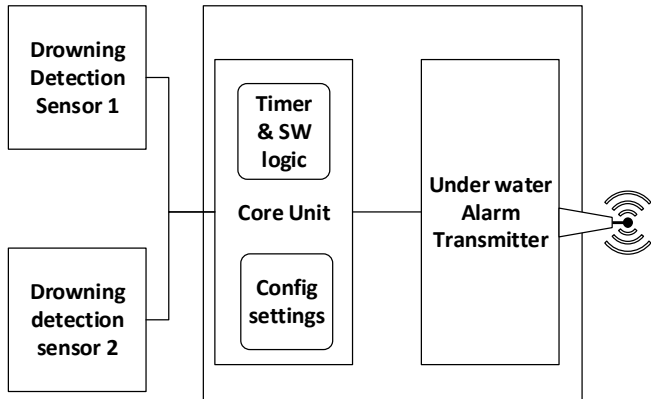

Fig. 3. Software Modules in goggles

Figure 3 shows the various software modules in the goggles. The input from both drowning sensors reaches the core unit. The core unit has a timer & SW logic module, Timer is started when both the drowning detectors are detected underwater the alarm unit will be triggered after the expiry of the timer. The time out values are software configurable and are saved in the Configuration settings. This timeout value is set by the user based on his breath holding capacity. The timer is reset if at least one of the sensors is out of the water. Once the timer is expired the alarm module is triggered. Underwater Alarm Transmitter unit will be triggered by the Core unit, if drowning is detected. The transmitter antennas starts transmitting the alarms that will be received by the receivers placed at various part of the lake/pool or ocean. This is diagrammatically explained in the below flowchart.

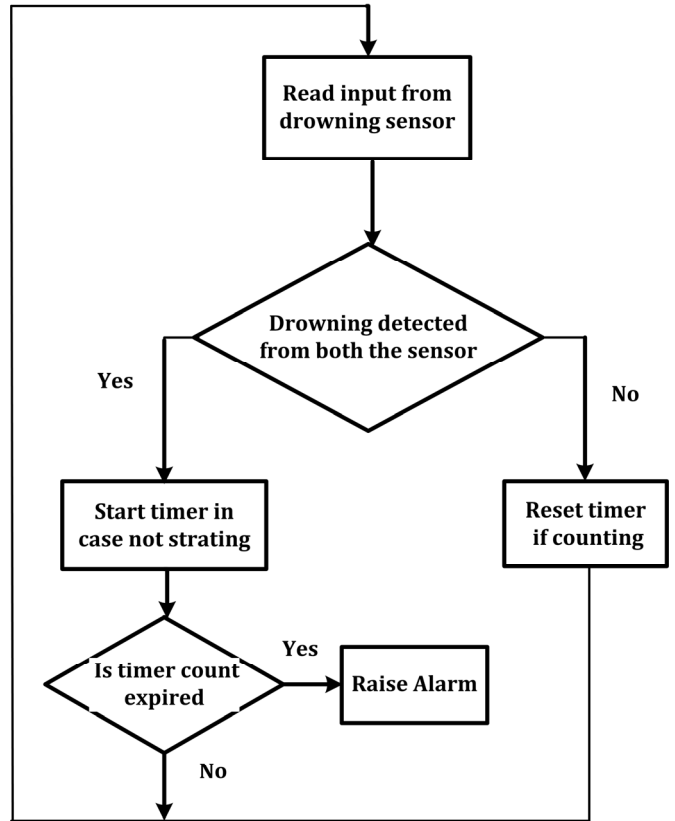

Fig. 4 Flow chart of Alarm trigger

#### IV. SIMULATION AND EXPERIMENTATION

Transmitter simulation circuit consists of the drowning detection sensor circuit, Arduino UNO board and alarm transmitter. The Arduino UNO board is using a microcontroller ATmega328P, which has 10bit resolution. The drowning detection circuit has two probes, one ground probe and the other sensing probe. Water presence has been simulated by using a switch. The BC547 NPN transistor turns ON the Arduino when the water presence simulation switch is turned ON. A counter also starts ticking at the presence of water. Once timed out the pin 13 goes high and acoustic transmitter starts transmitting. Figure 5 depicts the Transmitter Circuit glowing Green LED indicates that the person is inside water. The yellow LED indicates that transmitter is transmitting the signal.

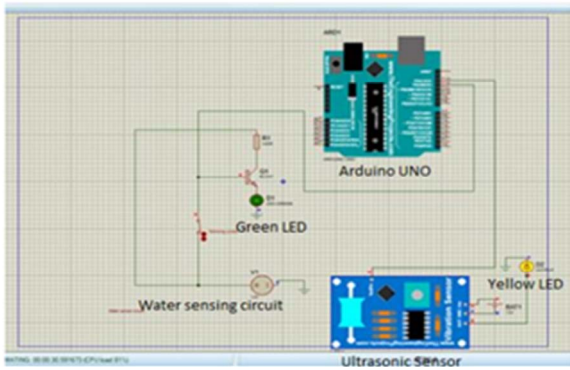

Fig. 5. Transmitter circuit simulation

The receiver part consists of a hydrophone, and an oscilloscope to record the output from the hydrophone. Hydrophone receives the signal from the transmitter, which triggers the buzzer by which we can identify the person drowning. The receiver circuit simulation is shown in figure 6 below.

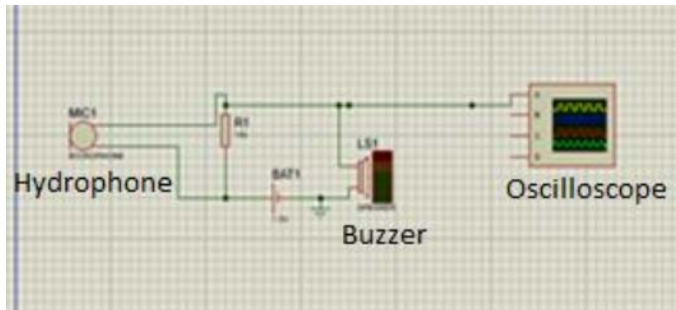

Fig. 6. Receiver circuit simulation

The experimentation setup consists of 3 units such as

- a) **Drowning detection sensor:** Sensor consists of a simple circuit to detect the presence of water. Output goes HIGH when water is detected and LOW in the presence of no water.
- b) **Transmitter:** Signals or information obtained from the detection sensor is transmitted for further process by Transmitter.
- c) **Receiver:** Ultrasonic waves of 40 kHz are received and convert the signal into useable form.

The drowning detection sensor and the Ultrasonic transmitters are both connected to the Arduino board. The board is programmed with a timer that simulates the user configurable breath holding time. When the drowning detection sensor comes in contact with the water, the timer is started. Another Arduino board is connected with the ultrasonic receiver. As the timer gets expired the ultrasonic transmitter transmits the signal to receiver. The ultrasonic communication was used for the experiment mainly because the miniature circuit will enable easy interfacing. This is also less prone to interference and noise. The ultrasonic module used was HC-SR04[13]. The Yellow LED in the Receiver board gets ON upon receiving of the signals. A audio siren is also programmed in the second

Arduino board to simulate drowning. The experimentation setup is shown in Figure 7.



Fig.7. Prototype unit of proposed DDM

V. RESULTS AND DISCUSSION

Figure 8 shows the output of the oscilloscope from the hydrophone. Waveform in yellow color is the output waveform received from the buzzer.

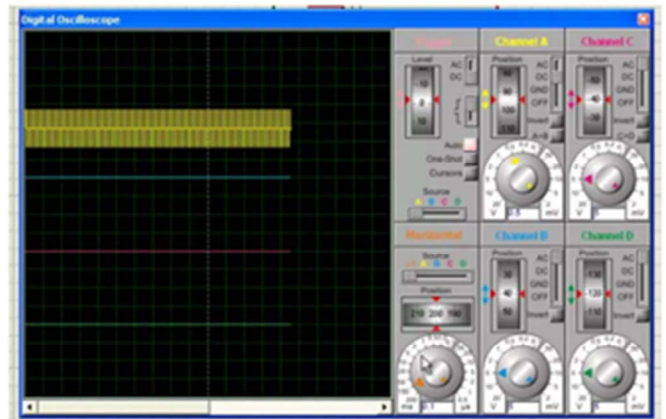

Fig. 8. Output of the prototype seen in Oscilloscope

The model was simulated using Proteus design suite to check its working before the actual physical prototype is constructed. The waveform in yellow colour is the output waveform received from the buzzer. The buzzer is triggered by receiving ultrasonic waves. The system is tested successfully, and the alert siren has been blown to alert the lifeguards. The drowning detection system will be ready to be used underwater when replaced it with the underwater module. According to statistics, the average time a child of age between 5-10 years can hold their breath for 10 sec underwater. We estimated the probability of danger based on the time for which the child is in water and plotted a graph between time and probability of danger. The probability of danger denotes threshold time. The same has been done for an adult, and the graph is plotted. We can infer two scenarios from this which are:

Scenario 1: Person comes out of water before the threshold time. In this case, the threshold time, i.e. time to withstand is 10 seconds. If the person comes out on or before 10 seconds,

the danger associated with him is zero, entire setup gets reset once he comes out of the water. From the graph, the time a person stays inside water is shown by an increasing slope, as soon as the person comes out the graph drops abruptly and comes to 0 probability of danger and remains the same until the person is above water.

The whole system is reset automatically when the person comes out of the water.

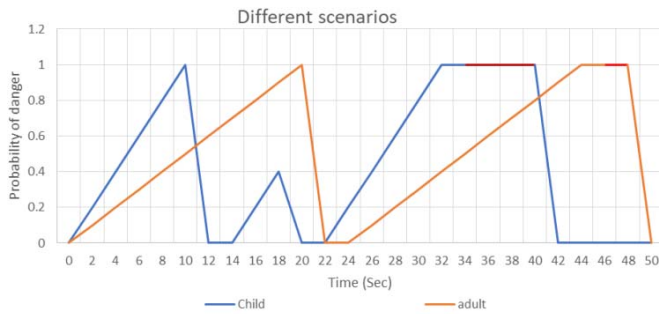

**Fig. 9. Scenario 1 and Scenario 2**

Scenario 2: Person doesn't come out of water before threshold time. In this case, if a person stays inside water for more than his threshold time, it indicates danger, this is shown in the graph using red color. An increasing slope shows the time a person stays inside water. If the person stays in water even after the threshold time, the value of probability of danger reaches 1 and remains constant thus indicating that the person is drowning. The whole system is reset automatically when the person is saved and brought out of water. Both the scenarios are depicted in Figure 9.

## VI. CONCLUSION

Life safety in water has been a concern for many centuries. Latest technology advancements has enabled us to come up with effective drowning detection systems. However many of those solutions are costly and limited to few. Survey reports show us that highest numbers of deaths are reported in low and middle income countries. The survey report also mentions the children have the largest death ratio compared to adults. Also the deaths reported in these incidents are more from open water bodies than closed water bodies like swimming pools.

The solution described above will be able to address these issues. The swimming goggles with drowning detection unit can be economically viable solution. The range of the alarms transmission can be improved by using underwater acoustics. Any age groups will be comfortable wearing the goggles, without hampering the recreational joy while swimming. The goggles can be useful even in sea. The alarm receivers can be placed at different locations in the water bodies which is having high chance of drowning. Another major advantage of this approach unlike other approach is the ease of use in all atmospheric conditions, like rain or wind to day or night. This solution is also a reliable solution where the life guards have difficulty to monitor the swimmers like a highly crowded sea.

This is one of the biggest challenges the lifeguards face. Many of the training to life guards includes how to monitor drowning in a large crowd like in beeches.

The future research plans include improving the underwater communication range by using various other technologies. This will enable to use this system in seas also. The alarm receivers can be easily connected to the buoy. With the help of establishing a standard communication protocol, we will be able to communicate more information to the lifeguards, as the name of the victim etc. This will help the lifeguard to search for his previous medical records as does the patient had any heart or lungs diseases etc. This information will provide an additional advantage while doing the rescue operation and while doing first aid. We also have plans to integrate a Global Positioning System (GPS) and pressure sensor. As pressure increases with the depth, the pressure reading will let the lifeguard know the depth at which victim is located. The GPS reading will be saved whenever the signal is available. If the system can tell the last previous GPS reading that was stored, it will enable the lifeguard to know what the approximate location of the victim. This feature will be very timesaving for lifeguards reducing their search time to near locations especially in case of lakes and oceans. However, this feature should be valid only if the GPS connectivity was alive with a minimum of 10 minutes before the drowning, as a very old GPS value will give a wrong location itself.

## REFERENCES

- [1] Global report on drowning [http://www.who.int/violence\\_injury\\_prevention/publications/drowning\\_global\\_report/Final\\_report\\_full\\_web.pdf](http://www.who.int/violence_injury_prevention/publications/drowning_global_report/Final_report_full_web.pdf) Jul 2018
- [2] 5 Stages of drowning <http://www.dedhamhealthfoundation.org/water/victim-recognition/stages-of-drowning/> Jul 2018
- [3] Life Guard Training <https://public.rcas.org/hs/chs/chshomework/Lists/Swimming/Attachments/805/Life%20Guard%20Training%201.docm> Jul 2018
- [4] Kingi wearables [http://www.kingii.com/kingii\\_wearable.html](http://www.kingii.com/kingii_wearable.html) Jul 2018
- [5] Zou Xu; Wang Tingjun; Liu Lujun; Liao Zhonghao; Fan Jiayang; Zhang Yuanfei; Zeng Shun, Swimming Pool Anti-Drowning Monitoring System. CN107134116A
- [6] Wai Kit Wong, Joe How Hui, Chu Kiong Loo and Way Soong Lim, "Off-time swimming pool surveillance using thermal imaging system", International journal of innovative computing, information and control, vol. 9 (3), 2013, pp. 366-371
- [7] Chi Zhang and Xiaoguang Li, "A Novel Camera-Based Drowning Detection Algorithm", Proceedings of Advances in Image and Graphics Technologies, Beijing, China, June 2015, pp. 224-233
- [8] Lei Fei, Wang Xueli and Chen Dongsheng, "Drowning Detection Based on Background Subtraction",

- International Conferences on Embedded Software and System, 2009, pp. 341-343
- [9] Alvin H. Kam, Wenmiao Lu and Wei-Yun Yau, "A Video-Based Drowning Detection System", Proceedings of the 7th European Conference on Computer Vision-Part IV, Copenhagen, Denmark, May 2002, pp. 297-311
- [10] Average breath holding time  
<https://www.normalbreathing.com/index-CP-normals.php>  
Jul 2018
- [11] Aboli Kulkarni, Kshitij Lakhani and Shubham Lokhande, "A Survey of Underwater Wireless Communication Technologies", Journal of communication and information systems, VOL. 31, NO. 1, 2016 page 242
- [12] Ian F. Akyildiz, Dario Pompili, Tommaso Melodia, Challenges for efficient communication in underwater acoustic sensor networks, ACM Sigbed Review 1 (2) (2004) 3-8
- [13] <https://www.mouser.com/ds/2/813/HCSR04-1022824.pdf>